



# Thermal Modelling Report



Revision H // 07/08/2023

## Slab NZBC R-Value and Passive House $\Psi$ and fRSI



# Contents

<b>Product Naming System</b>	<b>3</b>
<b>Climate Zone Boundaries</b>	<b>4</b>
<b>R-Value Requirements</b>	<b>5</b>
<b>Product R-Value Summary</b>	<b>6</b>
<b>QuickSet Taper</b>	<b>7</b>
QuickSet Taper 305/00 with QPOD	8
QuickSet Taper 305/00 with Polypod	9
QuickSet Taper 305/25 with QPOD	10
QuickSet Taper 305/25 with Polypod	11
QuickSet Taper 305/50 with QPOD	12
QuickSet Taper 305/50 with Polypod	13
QuickSet Taper 305/75 with Polypod	14
QuickSet Taper 305/100 with Polypod	15
<b>QuickSet Ultra</b>	<b>16</b>
QuickSet Ultra 305/00 with QPOD	17
QuickSet Ultra 305/00 with Polypod	18
QuickSet Ultra 305/25 with QPOD	19
QuickSet Ultra 305/25 with Polypod	20
QuickSet Ultra 305/50 with QPOD	21
QuickSet Ultra 305/50 with Polypod	22
QuickSet Ultra 305/75 with QPOD	23
QuickSet Ultra 305/75 with Polypod	24
QuickSet Ultra 305/100 with Polypod	25
QuickSet Ultra 305/150 (Continuous SlabX200) with QPOD	26
QuickSet Ultra 305/150 (Continuous SlabX200) with Polypod	27
<b>QuickSet Rebate</b>	<b>28</b>
QuickSet Rebate 120/305/00 with QPOD	29
QuickSet Rebate 120/305/00 with Polypod	30
QuickSet Rebate 120/305/25 with QPOD	31
QuickSet Rebate 120/305/25 with Polypod	32
QuickSet Rebate 120/305/50 with QPOD	33
QuickSet Rebate 120/305/50 with Polypod	34
QuickSet Rebate 120/305/75 with QPOD	35
QuickSet Rebate 120/305/75 with Polypod	36
QuickSet Rebate 120/305/100 with Polypod	37
QuickSet Rebate with Ultra 120/305/150 (Continuous SlabX200) with QPOD	38
QuickSet Rebate with Ultra 120/305/150 (Continuous SlabX200) with Polypod	39
<b>Methodology</b>	<b>40</b>

# Product Naming System

QuickSet **Taper** **305** / **00**

Cladding Type    Height (mm)    Base Insulation Thickness (mm)

In the naming system, the cladding type refers to the type of QuickSet system:

- **Taper** is for standard cladding;
- **Ultra** is for standard cladding but features an insulated top cap for 140mm framing and above;
- **Rebate** is for brick cladding.

The height value refers to the height of the formwork.

The final values after the slash denote the base insulation thickness, where 00 denotes no base insulation.

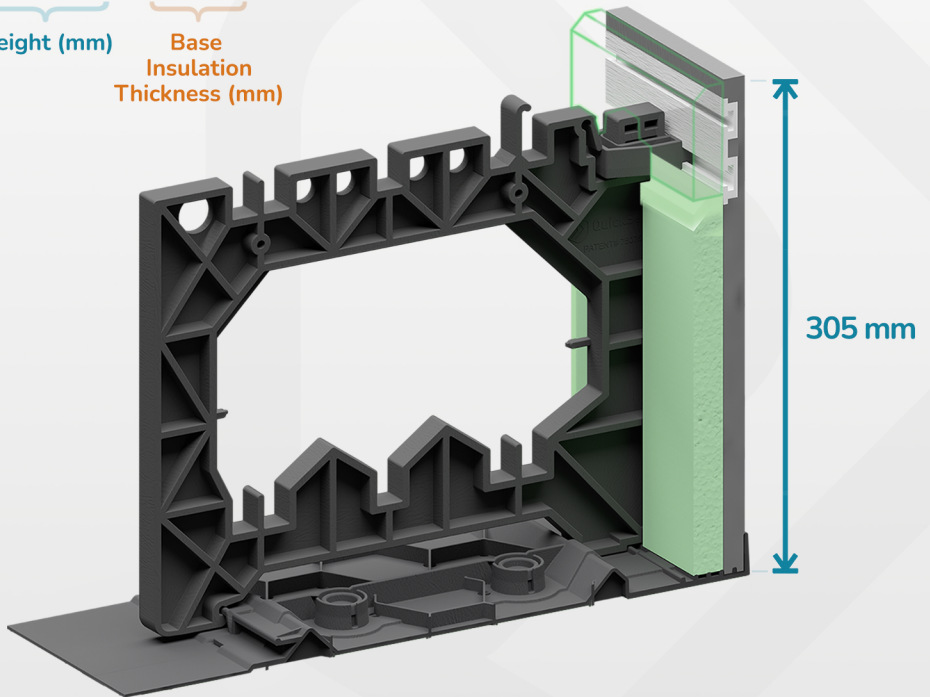

QuickSet **Rebate** **120** / **305** / **50**

Cladding Type    Rebate Size (mm)    Height (mm)    Base Insulation Thickness (mm)

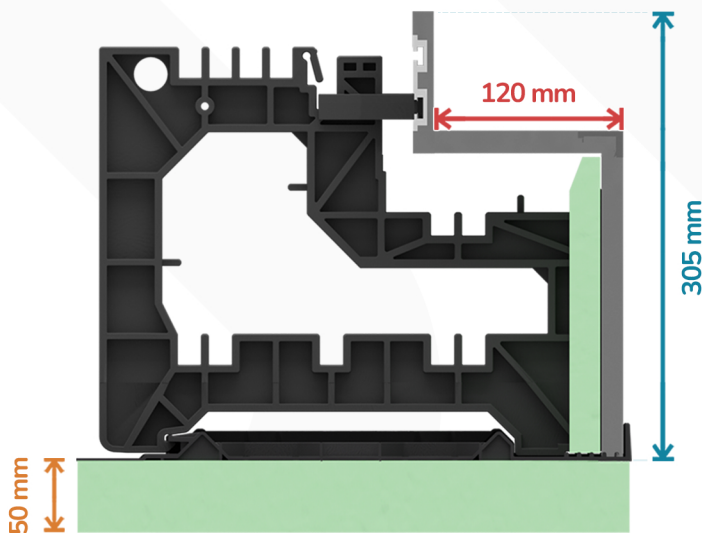

QuickSet **Ultra** **305** / **25**

Cladding Type    Height (mm)    Base Insulation Thickness (mm)

This is where the top cap for the QuickSet Ultra system is placed.

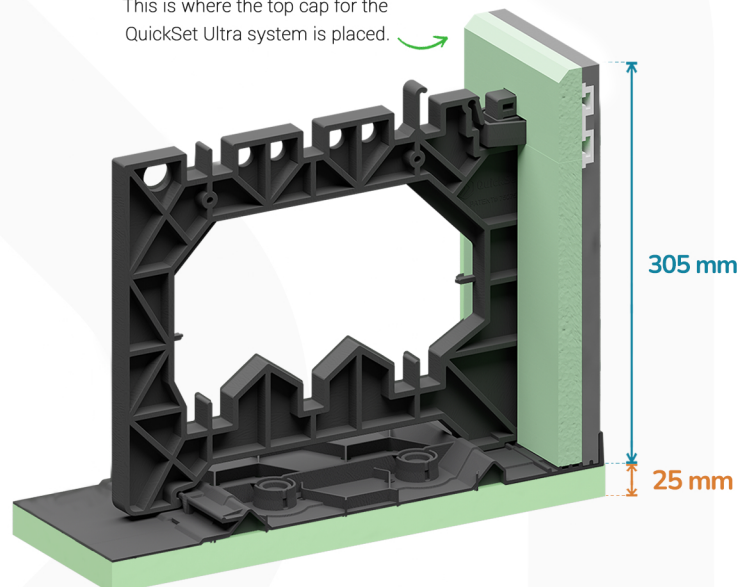

# Climate Zone Boundaries

Climate zone 1		Heated R2.5	Unheated R1.5
Climate zone 2		Heated R2.5	Unheated R1.5
Climate zone 3		Heated R2.5	Unheated R1.5
Climate zone 4		Heated R2.8	Unheated R1.5
Climate zone 5		Heated R3.0	Unheated R1.6
Climate zone 6		Heated R3.0	Unheated R1.7

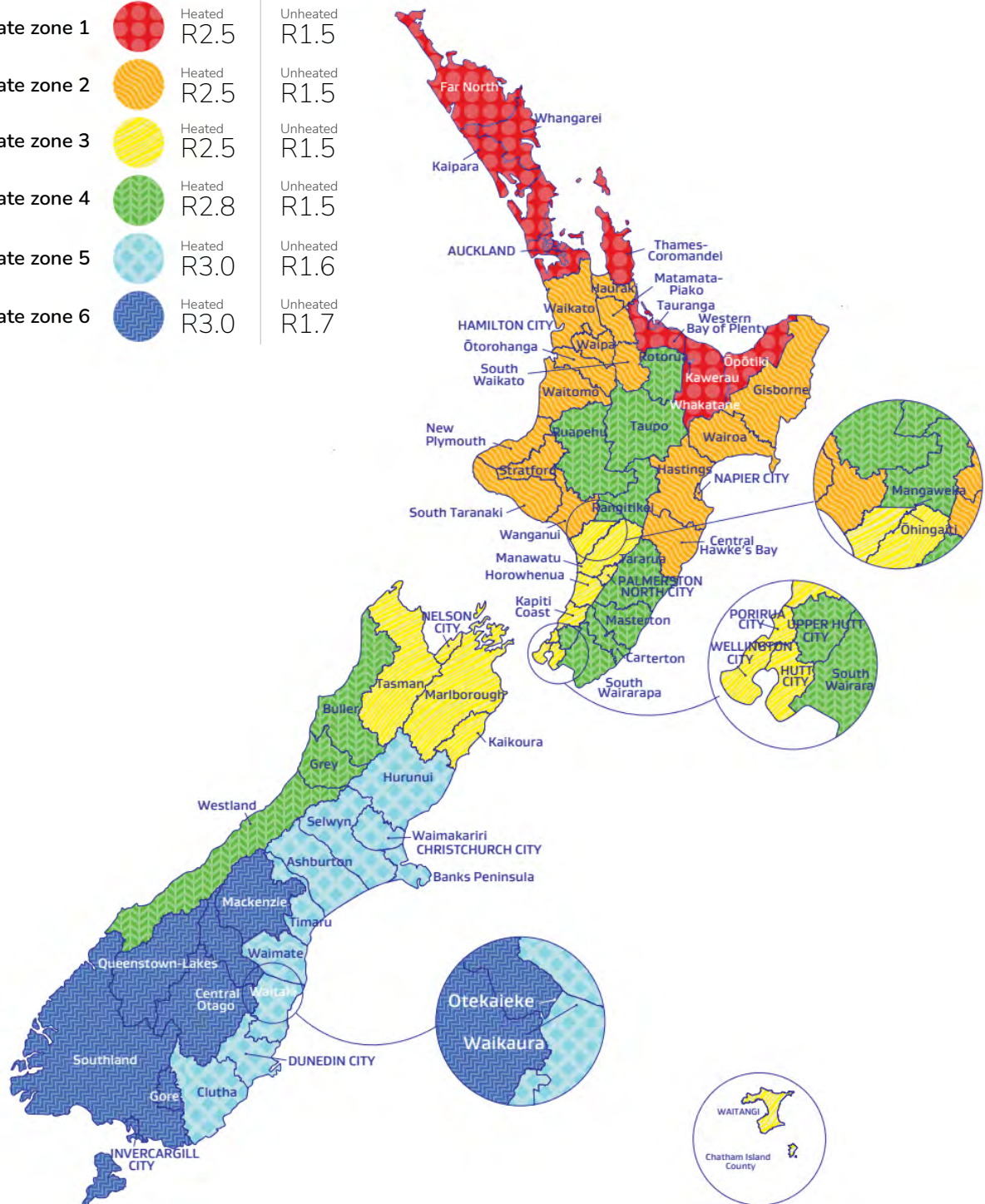

# R-Value Requirements

**Table 1.** Minimum construction R-values for heating ceilings, walls or floors.

Building element	Construction R-values (m <sup>2</sup> ·K/W) <sup>(1),(2),(3)</sup>					
	Climate zone 1	Climate zone 2	Climate zone 3	Climate zone 4	Climate zone 5	Climate zone 6
<i>Heated ceiling</i>	R6.6	R6.6	R6.6	R6.6	R6.6	R6.6
<i>Heated wall</i>	R2.9	R2.9	R2.9	R2.9	R2.9	R2.9
<i>Heated floor</i>	R2.5	R2.5	R2.5	R2.8	R3.0	R3.0

**Notes:**

(1)  $R_{in}/R\text{-value} < 0.1$  and  $R_{in}$  is the *thermal resistance* between the heated plane and the inside air.

(2) Floor coverings, for example carpet or cork, will reduce the efficiency of the *heated floor*.

(3) Climate zone boundaries are shown on page 4.

**Table 2.** Minimum construction R-values for building elements that do not contain embedded heating systems.

Building element	Construction R-values (m <sup>2</sup> ·K/W) <sup>(1)</sup>					
	Climate zone 1	Climate zone 2	Climate zone 3	Climate zone 4	Climate zone 5	Climate zone 6
<i>Roof</i>	R6.6	R6.6	R6.6	R6.6	R6.6	R6.6
<i>Wall</i>	R2.0	R2.0	R2.0	R2.0	R2.0	R2.0
<b>Floor</b>						
<i>Slab-on-ground floors</i>	R1.5	R1.5	R1.5	R1.5	R1.6	R1.7
<i>Floors other than slab-on-ground</i>	R2.5	R2.5	R2.5	R2.8	R3.0	R3.0
<i>Windows and doors</i>	R0.46	R0.46	R0.46	R0.46	R0.50	R0.50
<i>Skylights</i>	R0.46	R0.46	R0.54	R0.54	R0.62	R0.62

**Notes:**

(1) Climate zone boundaries are shown on page 4.

# Product R-Value Summary

<b>A/P Ratio</b>	<b>1.0</b>	<b>1.6</b>	<b>1.8</b>	<b>2.0</b>	<b>2.2</b>	<b>2.4</b>	<b>2.6</b>	<b>2.8</b>	<b>3.0</b>	<b>3.6</b>	<b>4.0</b>
QuickSet Taper 305/00 with QPOD	0.74	0.96	1.03	1.11	1.18	1.24	1.31	1.37	1.44	1.63	1.76
QuickSet Taper 305/00 with Polypod	0.85	1.11	1.20	1.29	1.36	1.44	1.51	1.58	1.66	1.86	2.00
QuickSet Taper 305/25 with QPOD	1.06	1.36	1.46	1.55	1.63	1.71	1.79	1.87	1.95	2.17	2.32
QuickSet Taper 305/25 with Polypod	1.07	1.40	1.52	1.63	1.71	1.80	1.88	1.97	2.05	2.28	2.43
QuickSet Taper 305/50 with QPOD	1.21	1.57	1.70	1.82	1.92	2.03	2.13	2.23	2.34	2.59	2.76
QuickSet Taper 305/50 with Polypod	1.28	1.68	1.81	1.95	2.06	2.17	2.29	2.40	2.51	2.78	2.95
QuickSet Taper 305/75 with Polypod	1.35	1.81	1.96	2.12	2.22	2.33	2.44	2.55	2.66	2.94	3.12
QuickSet Taper 305/100 with Polypod	1.42	1.90	2.06	2.22	2.33	2.45	2.57	2.69	2.81	3.16	3.39
QuickSet Ultra 305/00 with QPOD	0.82	1.06	1.14	1.21	1.28	1.35	1.42	1.49	1.56	1.77	1.90
QuickSet Ultra 305/00 with Polypod	0.97	1.24	1.33	1.42	1.50	1.58	1.65	1.73	1.81	2.02	2.17
QuickSet Ultra 305/25 with QPOD	1.29	1.61	1.72	1.83	1.91	2.00	2.08	2.16	2.25	2.48	2.63
QuickSet Ultra 305/25 with Polypod	1.42	1.79	1.92	2.04	2.13	2.22	2.31	2.40	2.49	2.74	2.90
QuickSet Ultra 305/50 with QPOD	1.62	2.03	2.17	2.30	2.40	2.50	2.60	2.69	2.79	3.05	3.23
QuickSet Ultra 305/50 with Polypod	1.73	2.15	2.30	2.44	2.56	2.67	2.79	2.91	3.02	3.30	3.48
QuickSet Ultra 305/75 with QPOD	1.76	2.20	2.35	2.49	2.59	2.70	2.80	2.90	3.00	3.27	3.45
QuickSet Ultra 305/75 with Polypod	1.95	2.46	2.62	2.79	2.93	3.07	3.21	3.34	3.48	3.79	4.00
QuickSet Ultra 305/100 with Polypod	2.03	2.60	2.79	2.98	3.11	3.24	3.36	3.49	3.61	3.93	4.13
QuickSet Ultra 305/150 (Continuous SlabX200) with QPOD	2.17	2.81	3.03	3.24	3.39	3.54	3.69	3.84	3.99	4.35	4.60
QuickSet Ultra 305/150 (Continuous SlabX200) with Polypod	2.31	3.02	3.26	3.50	3.66	3.83	3.99	4.16	4.32	4.72	4.98
QuickSet Rebate 120/305/00 with QPOD	0.81	1.05	1.13	1.21	1.28	1.35	1.42	1.49	1.56	1.76	1.90
QuickSet Rebate 120/305/00 with Polypod	0.98	1.25	1.35	1.44	1.51	1.59	1.67	1.75	1.82	2.04	2.18
QuickSet Rebate 120/305/25 with QPOD	1.22	1.53	1.63	1.74	1.82	1.90	1.99	2.07	2.16	2.39	2.54
QuickSet Rebate 120/305/25 with Polypod	1.33	1.70	1.83	1.95	2.04	2.13	2.22	2.31	2.40	2.65	2.81
QuickSet Rebate 120/305/50 with QPOD	1.48	1.84	1.96	2.08	2.19	2.30	2.41	2.52	2.63	2.89	3.06
QuickSet Rebate 120/305/50 with Polypod	1.61	2.00	2.14	2.27	2.39	2.51	2.63	2.75	2.86	3.14	3.32
QuickSet Rebate 120/305/75 with QPOD	1.54	1.98	2.13	2.28	2.38	2.49	2.59	2.69	2.80	3.07	3.25
QuickSet Rebate 120/305/75 with Polypod	1.66	2.15	2.31	2.47	2.59	2.70	2.81	2.92	3.03	3.32	3.51
QuickSet Rebate 120/305/100 with Polypod	1.78	2.30	2.47	2.65	2.79	2.93	3.07	3.21	3.35	3.67	3.88
QuickSet Rebate with Ultra 120/305/150 (Continuous SlabX200) with QPOD	1.99	2.63	2.84	3.05	3.20	3.35	3.50	3.65	3.80	4.16	4.41
QuickSet Rebate with Ultra 120/305/150 (Continuous SlabX200) with Polypod	2.21	2.92	3.15	3.39	3.55	3.72	3.88	4.04	4.21	4.61	4.87

# QuickSet Taper

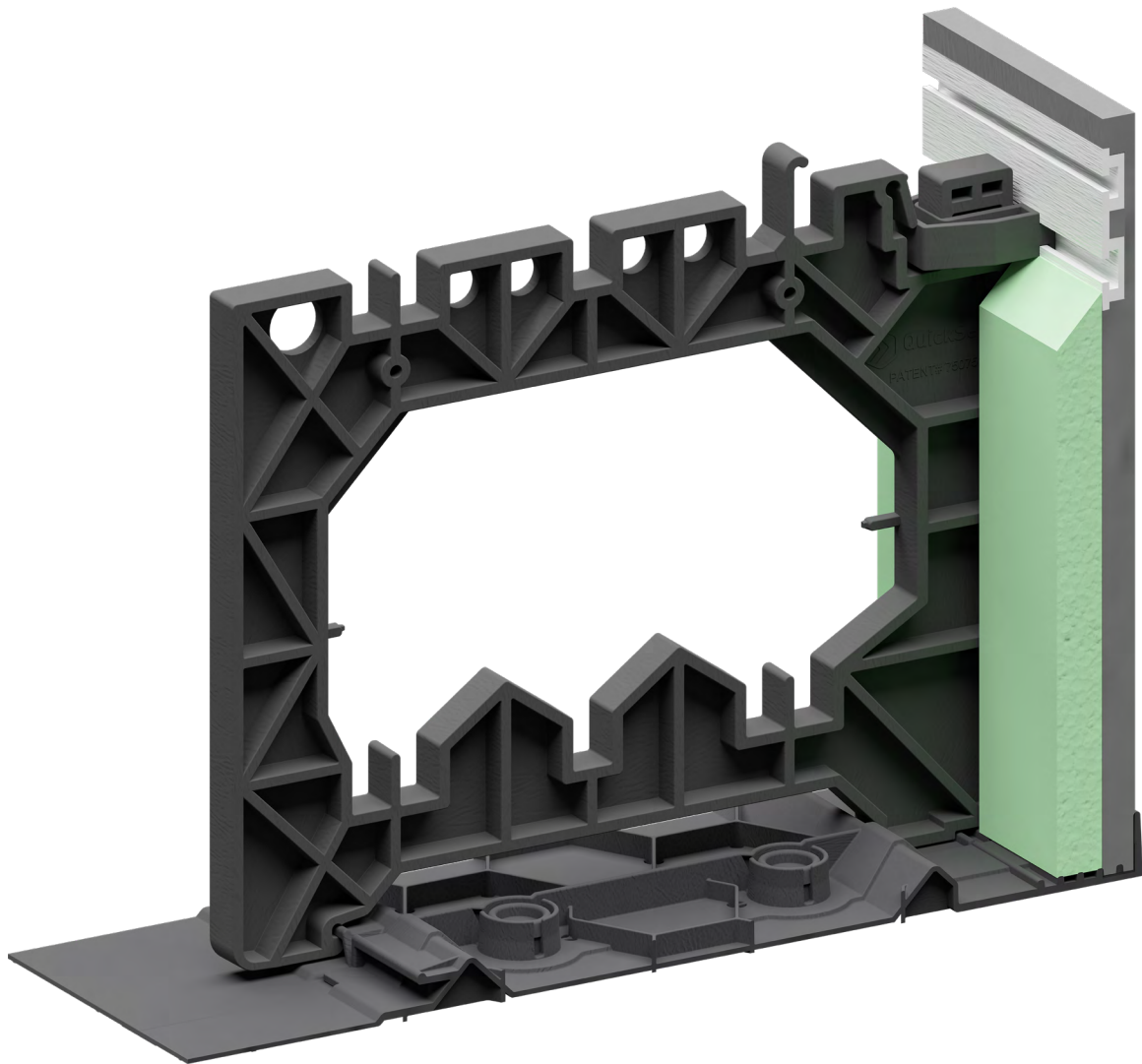

- Height options of 305, 320, 340, 385, or 400mm;
- Suitable for 220mm and 300mm pod systems;
- Compatible with 90mm framing.

# QuickSet Taper 305/00 with QPOD

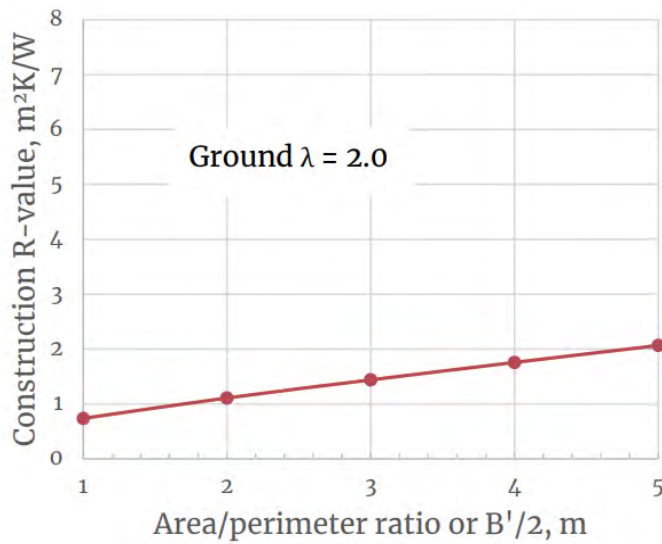
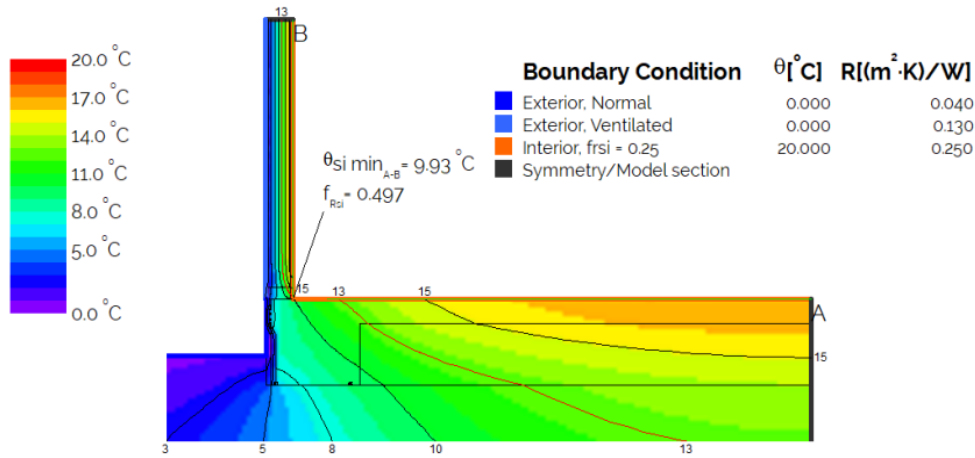

A/P, m	R-value, m²K/W
1	0.74
1.6	0.96
1.8	1.03
2	1.11
2.2	1.18
2.4	1.24
2.6	1.31
2.8	1.37
3	1.44
3.2	1.50
3.4	1.57
3.6	1.63
3.8	1.69
4	1.76
5	2.06

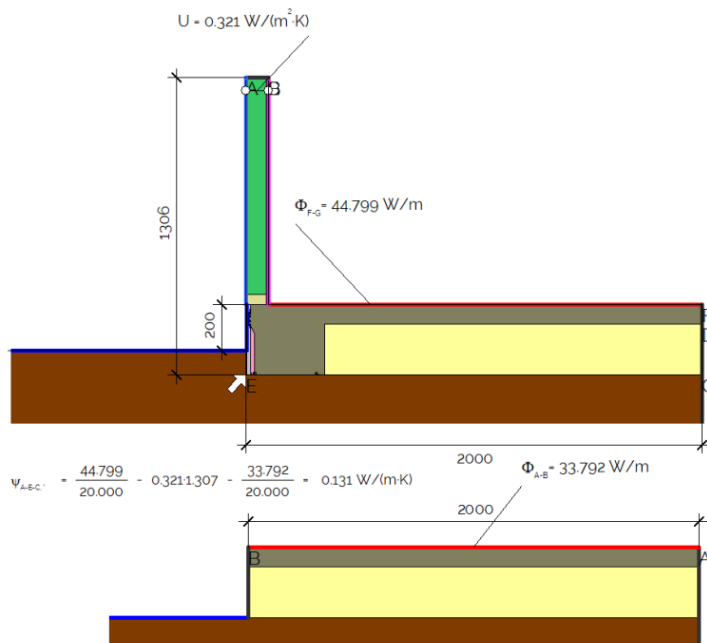

Boundary Condition	$\theta [^{\circ}\text{C}]$	$R [(\text{m}^2\cdot\text{K})/\text{W}]$
Exterior, Normal	0.000	0.040
Exterior, Ventilated	0.000	0.130
Interior, heat flux, downwards	20.000	0.170
Interior, normal, horizontal	20.000	0.130
Symmetry/Model section		

Material	$\lambda [W/(m\cdot K)]$
Aluminium	160.000
Concrete	2.000
Ground	2.000
PVC Foam board	0.100
Plasterboard	0.250
Polypropylene	0.220
QPod_4open	1.050
Timber (Softwood)	0.130
Wall insulation	0.032
XPSinsul_L0.028	0.028



# QuickSet Taper 305/00 with Polypod

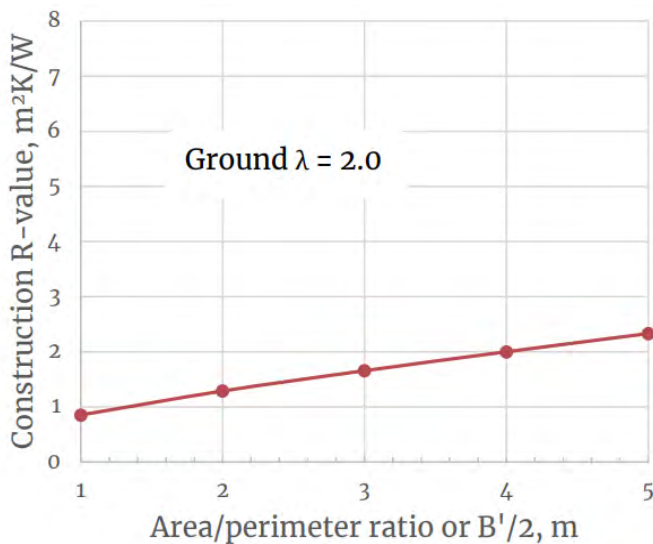
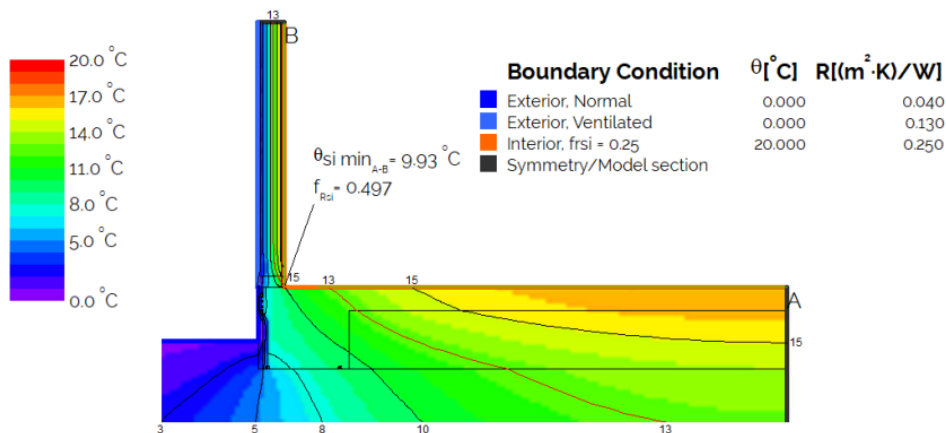

A/P, m	R-value, m <sup>2</sup> K/W
1	0.85
1.6	1.11
1.8	1.20
2	1.29
2.2	1.36
2.4	1.44
2.6	1.51
2.8	1.58
3	1.66
3.2	1.73
3.4	1.79
3.6	1.86
3.8	1.93
4	2.00
5	2.33

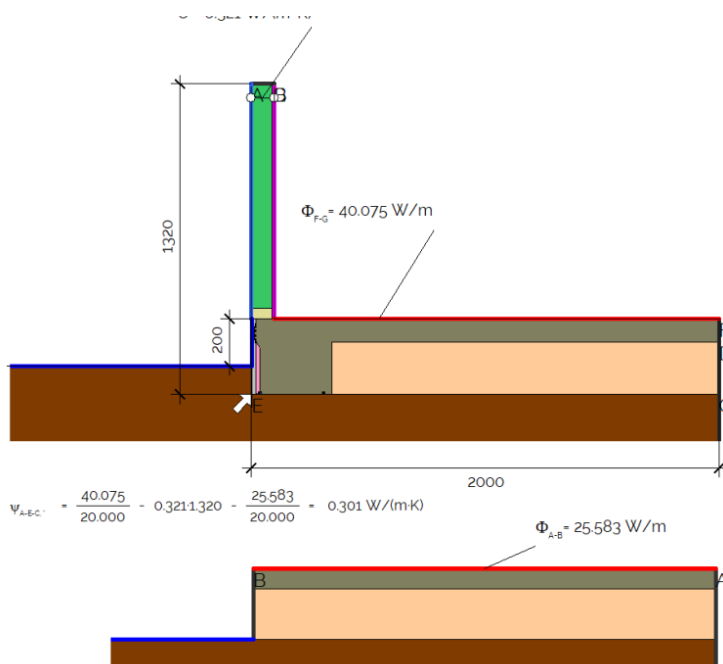

Boundary Condition	θ <sub>i</sub> [°C]	R [(m <sup>2</sup> ·K)/W]
Exterior, Normal	0.000	0.040
Exterior, Ventilated	0.000	0.130
Interior, heat flux, downwards	20.000	0.170
Interior, normal, horizontal	20.000	0.130
Symmetry/Model section		

  

Material	λ [W/(m·K)]
Aluminium	160.000
Concrete	2.000
Ground	2.000
PVC Foam board	0.100
Plasterboard	0.250
Poly Pod	0.395
Polypropylene	0.220
Timber (Softwood)	0.130
Wall insulation	0.032
XPSInsul_Lo.028	0.028

# QuickSet Taper 305/25 with QPOD

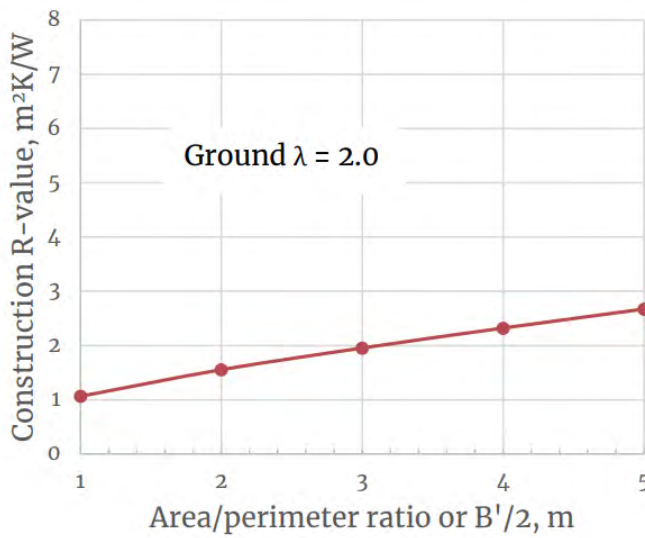
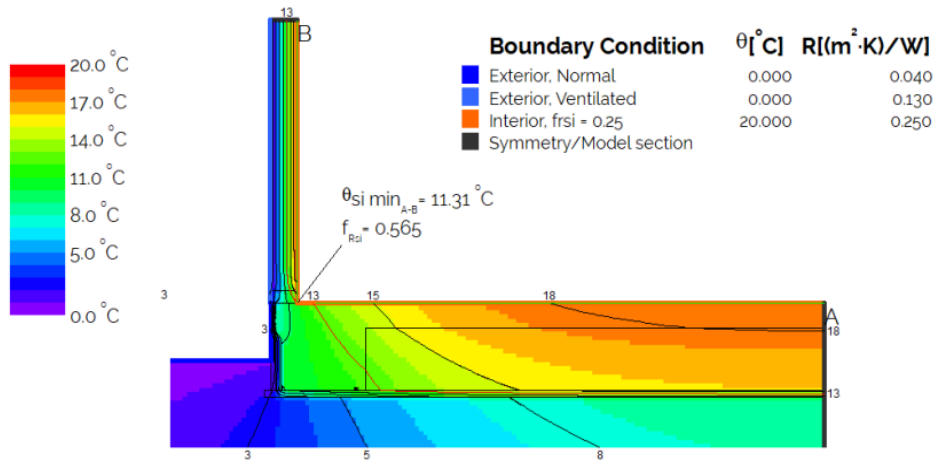

A/P, m	R-value, m²K/W
1	1.06
1.6	1.36
1.8	1.46
2	1.55
2.2	1.63
2.4	1.71
2.6	1.79
2.8	1.87
3	1.95
3.2	2.03
3.4	2.10
3.6	2.17
3.8	2.25
4	2.32
5	2.67

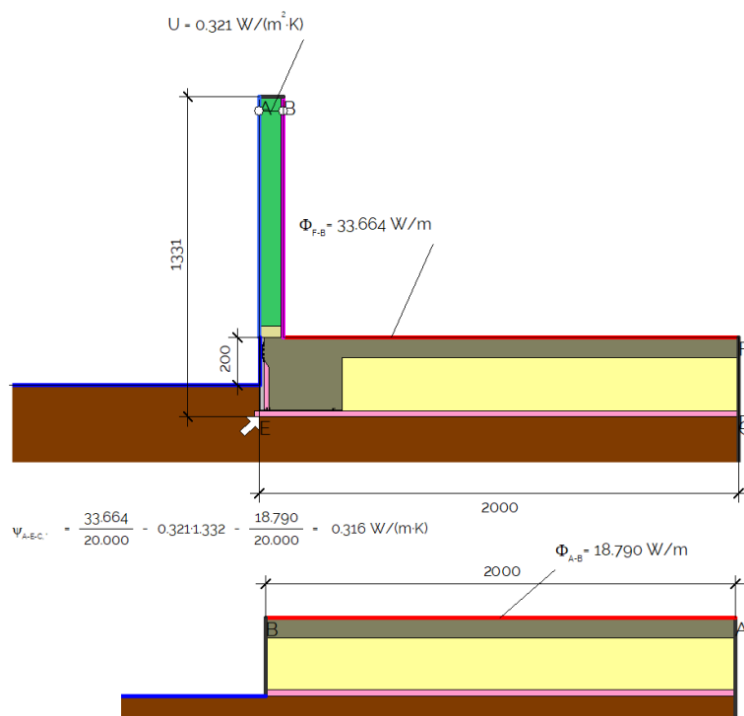

Boundary Condition	$\theta [^{\circ}\text{C}]$	$R[(\text{m}^2 \cdot \text{K})/\text{W}]$
Exterior, Normal	0.000	0.040
Exterior, Ventilated	0.000	0.130
Interior, heat flux, downwards	20.000	0.170
Interior, normal, horizontal	20.000	0.130
Symmetry/Model section		

  

Material	$\lambda [W/(m \cdot K)]$
Aluminium	160.000
Concrete	2.000
Ground	2.000
PVC Foam board	0.100
Plasterboard	0.250
Polypropylene	0.220
QPod_4open	1.050
Timber (Softwood)	0.130
Wall insulation	0.032
XPSinsul_L.0.028	0.028

# QuickSet Taper 305/25 with Polypod

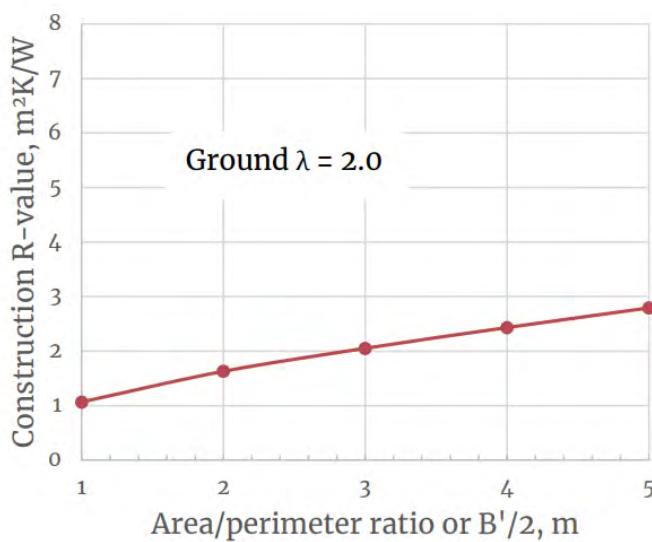
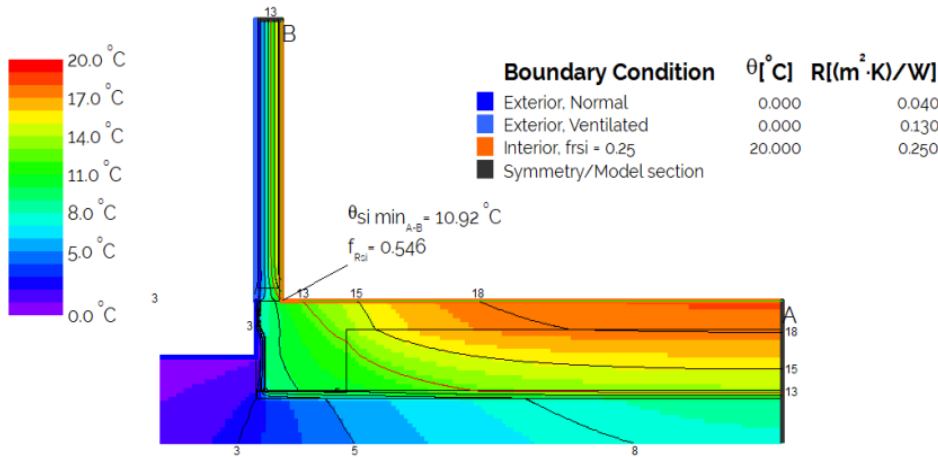

A/P, m	R-value, $\text{m}^2\text{K}/\text{W}$
1	1.07
1.6	1.40
1.8	1.52
2	1.63
2.2	1.71
2.4	1.80
2.6	1.88
2.8	1.97
3	2.05
3.2	2.13
3.4	2.20
3.6	2.28
3.8	2.36
4	2.43
5	2.79

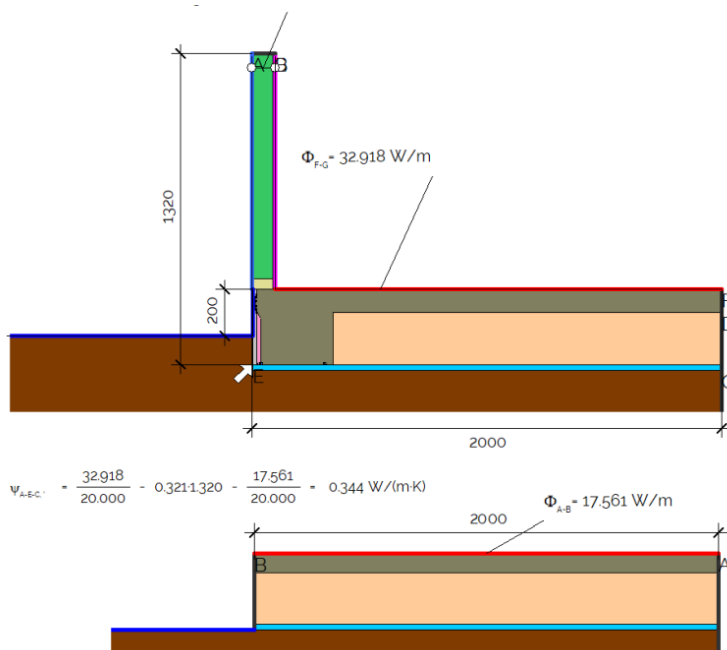

Boundary Condition	$\theta [^{\circ}\text{C}]$	$R [(\text{m}^2 \cdot \text{K})/\text{W}]$
Exterior, Normal	0.000	0.040
Exterior, Ventilated	0.000	0.130
Interior, heat flux, downwards	20.000	0.170
Interior, normal, horizontal	20.000	0.130
Symmetry/Model section		

  

Material	$\lambda [W]/(\text{m} \cdot \text{K})$
Aluminium	160.000
Concrete	2.000
EPS H	0.036
Ground	2.000
PVC Foam board	0.100
Plasterboard	0.250
Poly Pod	0.395
Polypropylene	0.220
Timber (Softwood)	0.130
Wall insulation	0.032
XPSinsul_L0.028	0.028

# QuickSet Taper 305/50 with QPOD

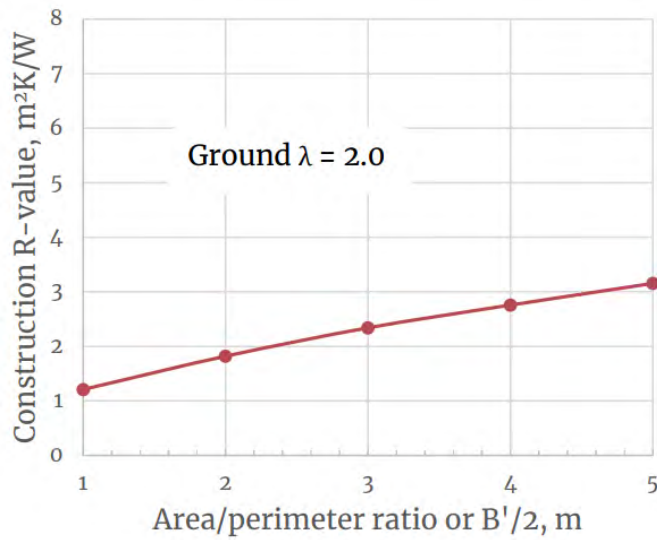
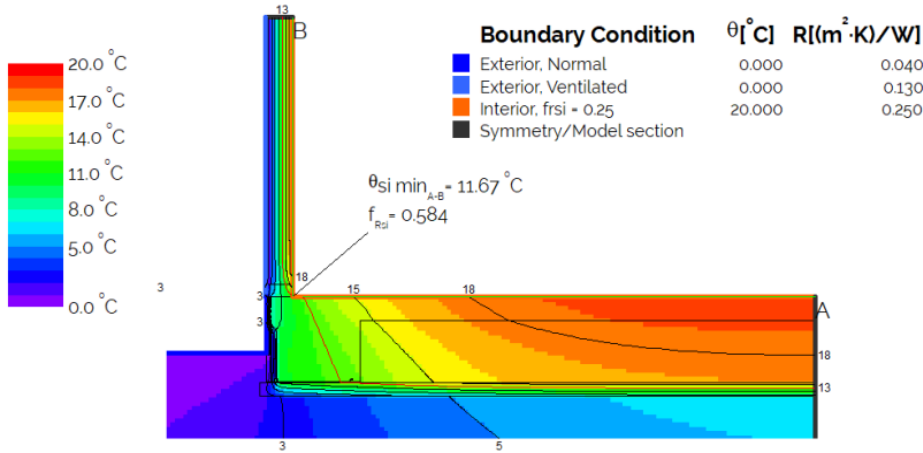

A/P, m	R-value, m²K/W
1	1.21
1.6	1.57
1.8	1.70
2	1.82
2.2	1.92
2.4	2.03
2.6	2.13
2.8	2.23
3	2.34
3.2	2.42
3.4	2.51
3.6	2.59
3.8	2.67
4	2.76
5	3.15

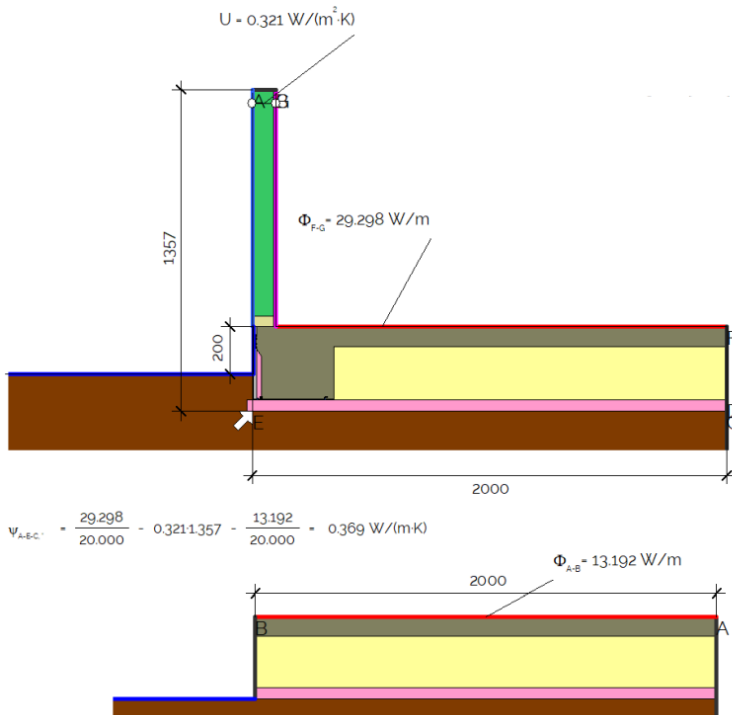

Boundary Condition	θ [°C]	R [(m²·K)/W]
Exterior, Normal	0.000	0.040
Exterior, Ventilated	0.000	0.130
Interior, heat flux, downwards	20.000	0.170
Interior, normal, horizontal	20.000	0.130
Symmetry/Model section		

  

Material	λ [W/(m·K)]
Aluminium	160.000
Concrete	2.000
Ground	2.000
PVC Foam board	0.100
Plasterboard	0.250
Polypropylene	0.220
QPod_4open	1.050
Timber (Softwood)	0.130
Wall insulation	0.032
XPSInsul_L0.028	0.028

# QuickSet Taper 305/50 with Polypod

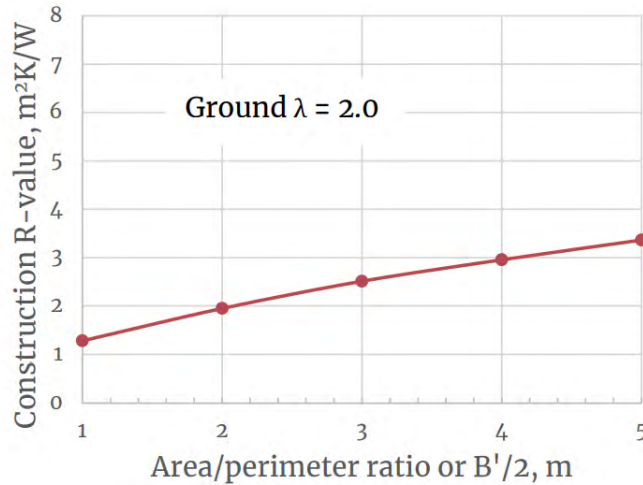
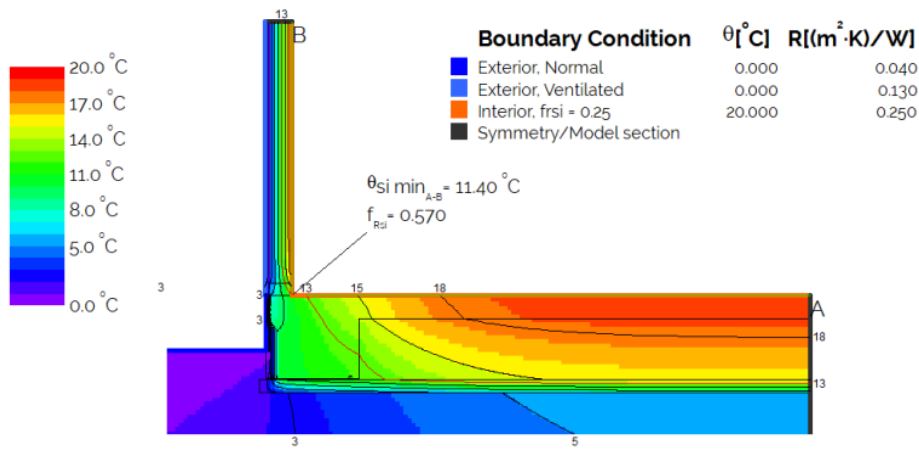

A/P, m	R-value, m²K/W
1	1.28
1.6	1.68
1.8	1.81
2	1.95
2.2	2.06
2.4	2.17
2.6	2.29
2.8	2.40
3	2.51
3.2	2.60
3.4	2.69
3.6	2.78
3.8	2.87
4	2.95
5	3.36

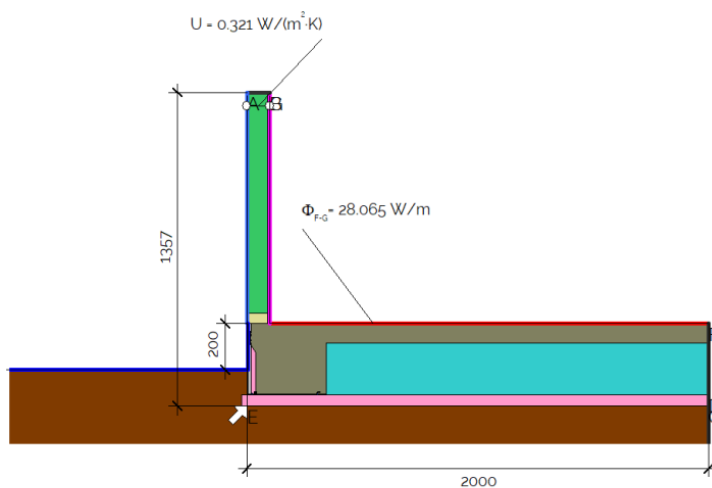

Boundary Condition	θ [°C]	R [(m²·K)/W]
Exterior, Normal	0.000	0.040
Exterior, Ventilated	0.000	0.130
Interior, heat flux, downwards	20.000	0.170
Interior, normal, horizontal	20.000	0.130
Symmetry/Model section		

Material	λ [W/(m·K)]
Aluminium	160.000
Concrete	2.000
Ground	2.000
PVC Foam board	0.100
Plasterboard	0.250
Polypropylene	0.220
Timber (Softwood)	0.130
WFPg9g-0.038/220/1100/SOIL	0.407
Wall insulation	0.032
XPSinsu_Lo.028	0.028

$$\Psi_{A-E-C} = \frac{28.065}{20.000} - 0.321 \cdot 1357 - \frac{11.880}{20.000} = 0.373 \text{ W}/(\text{m} \cdot \text{K})$$

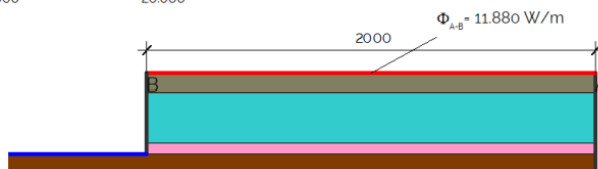

# QuickSet Taper 305/75 with Polypod

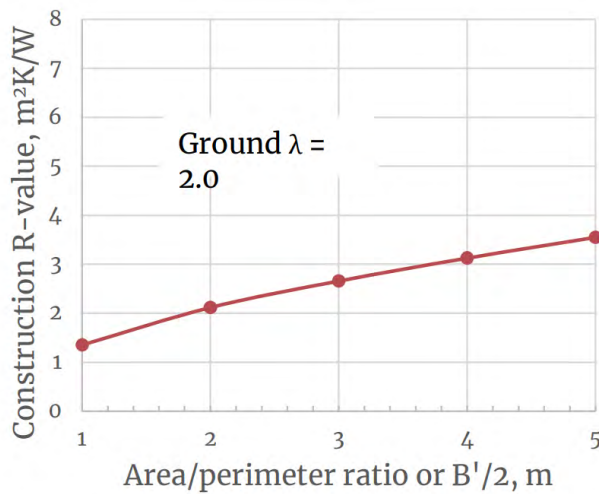
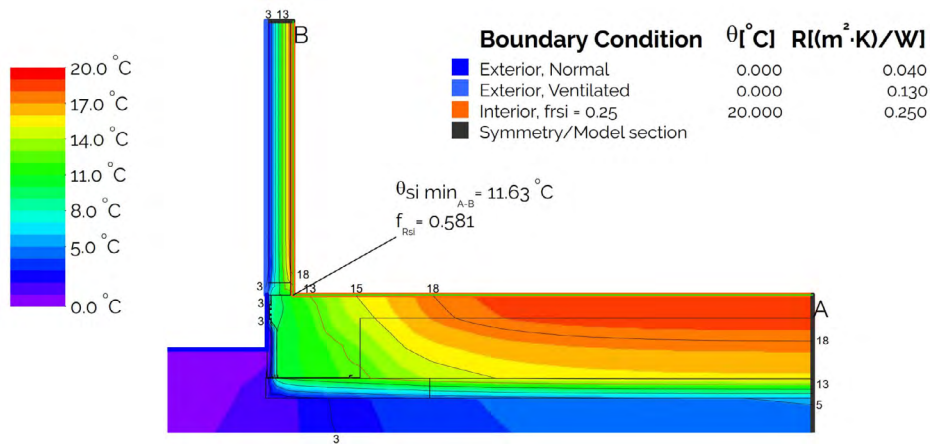

A/P, m	R-value, $\text{m}^2\text{K}/\text{W}$
1	1.35
1.6	1.81
1.8	1.96
2	2.12
2.2	2.22
2.4	2.33
2.6	2.44
2.8	2.55
3	2.66
3.2	2.75
3.4	2.84
3.6	2.94
3.8	3.03
4	3.12
5	3.55

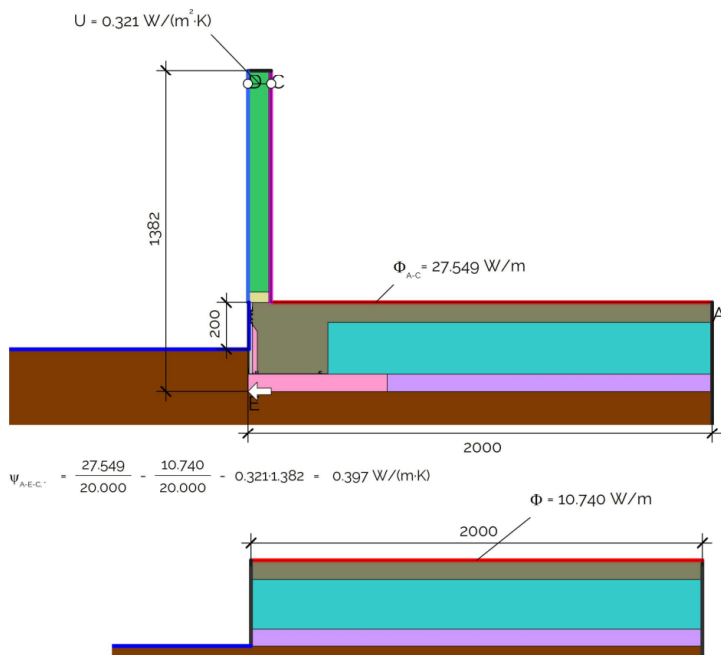

Boundary Condition	$\theta_i [^\circ\text{C}]$	$R[(\text{m}^2 \cdot \text{K})/\text{W}]$
Exterior, Normal	0.000	0.040
Exterior, Ventilated	0.000	0.130
Interior, heat flux, downwards	20.000	0.170
Interior, normal, horizontal	20.000	0.130
Symmetry/Model section		

  

Material	$\lambda [\text{W}/(\text{m}\cdot\text{K})]$
Aluminium	160.000
Concrete	2.000
EPS VH-grade	0.035
Ground	2.000
PVC Foam board	0.100
Plasterboard	0.250
Polypropylene	0.220
Timber (Softwood)	0.130
WFPg9g-0.038/220/1100/SOIL	0.407
Wall insulation	0.032
XPSInsul_L0.028	0.028

# QuickSet Taper 305/100 with Polypod

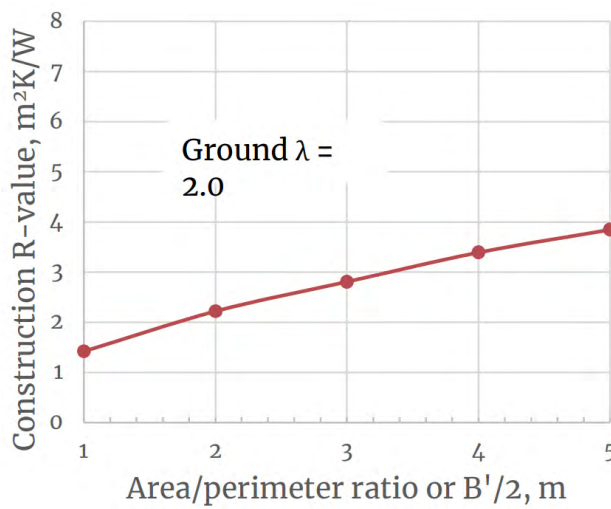
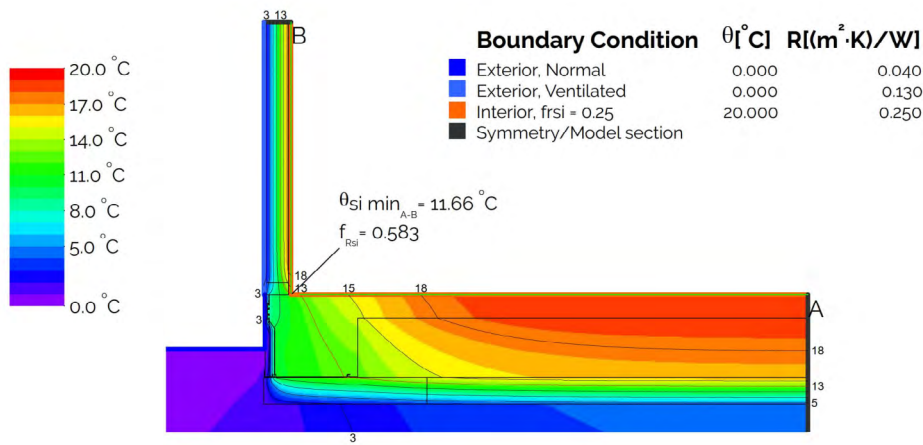

A/P, m	R-value, m²K/W
1	1.42
1.6	1.90
1.8	2.06
2	2.22
2.2	2.33
2.4	2.45
2.6	2.57
2.8	2.69
3	2.81
3.2	2.92
3.4	3.04
3.6	3.16
3.8	3.27
4	3.39
5	3.85

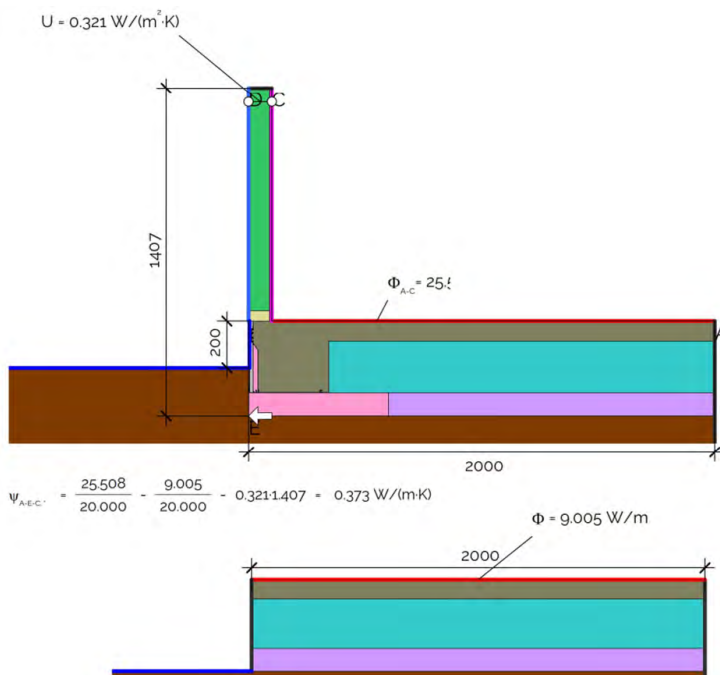

Boundary Condition	θ [°C]	R [(m²·K)/W]
Exterior, Normal	0.000	0.040
Exterior, Ventilated	0.000	0.130
Interior, heat flux, downwards	20.000	0.170
Interior, normal, horizontal	20.000	0.130
Symmetry/Model section		

Material	λ [W/(m·K)]
Aluminium	160.000
Concrete	2.000
EPS VH-grade	0.035
Ground	2.000
PVC Foam board	0.100
Plasterboard	0.250
Polypropylene	0.220
Timber (Softwood)	0.130
WFP9x9-0.038/220/1100/SOIL	0.407
Wall insulation	0.032
XPSinsul_L0.028	0.028

$$\psi_{A-E-C} = \frac{25.508}{20.000} - \frac{9.005}{20.000} - 0.321 \cdot 1407 = 0.373 \text{ W/(m}^2\cdot\text{K)}$$

# QuickSet Ultra

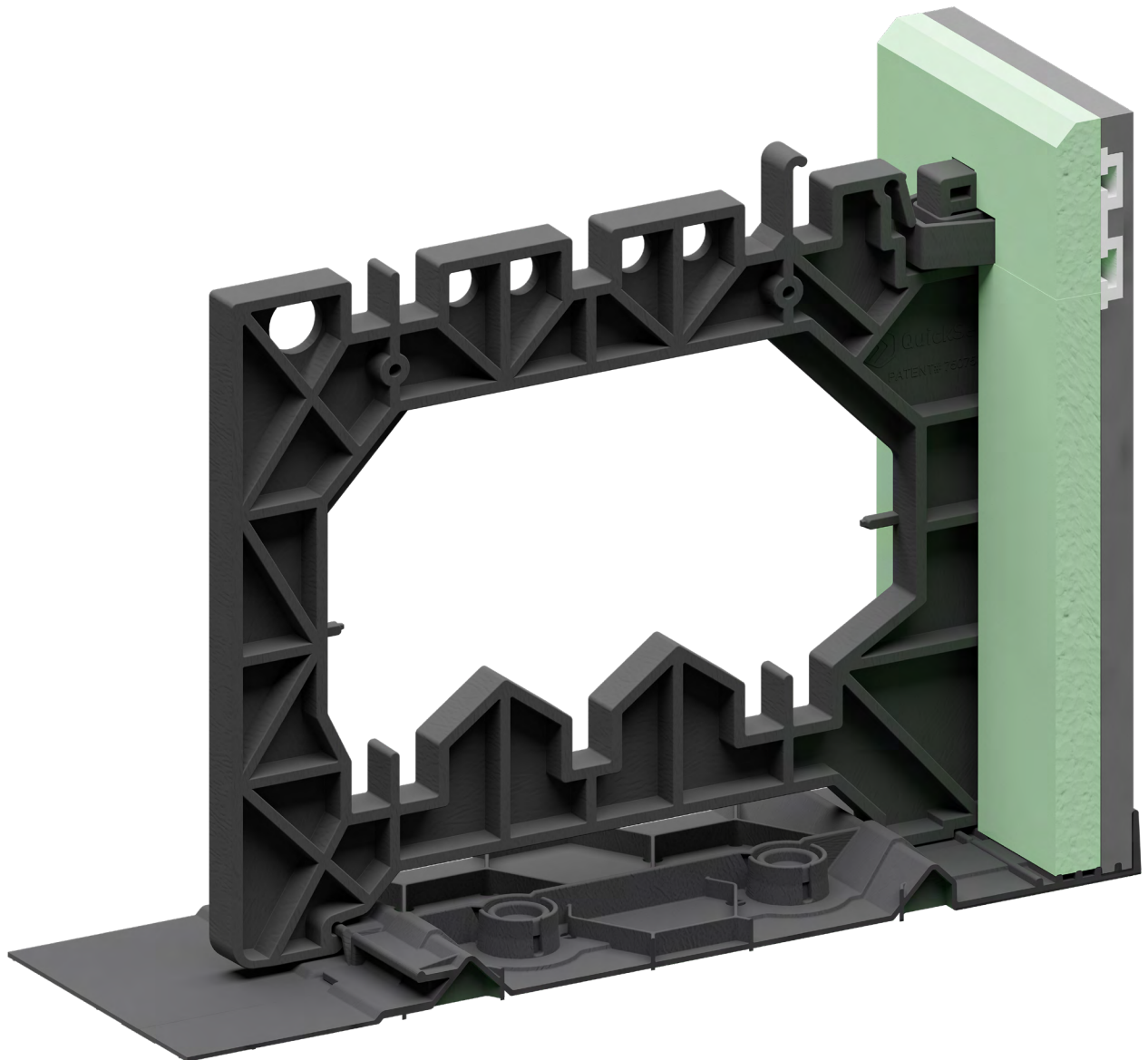

- Height options of 305, 320, 340, 385, or 400mm;
- Suitable for 220mm and 300mm pod systems;
- Compatible with 140mm framing and above;
- Additional back insulation.



# QuickSet Ultra 305/00 with QPOD

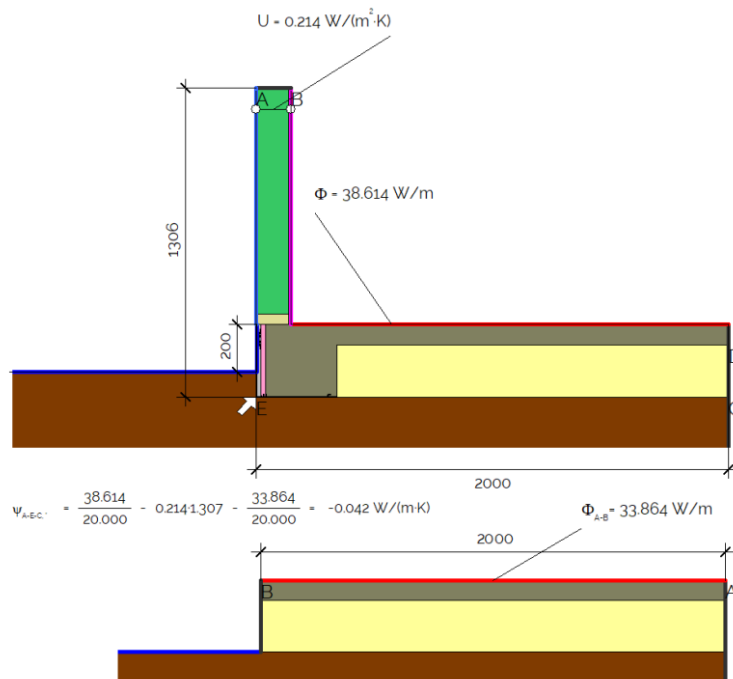
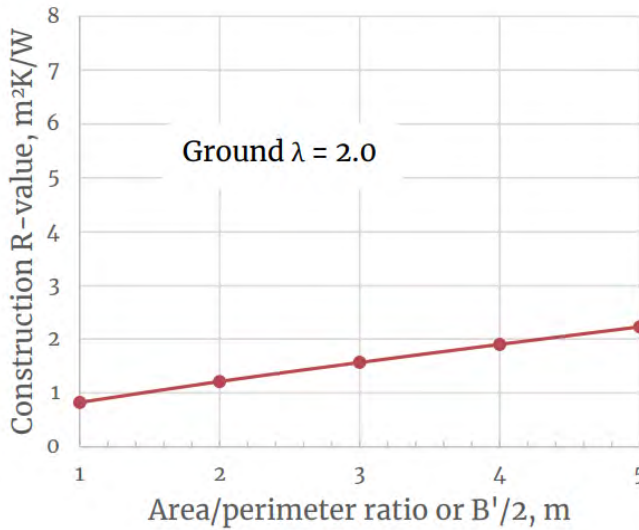
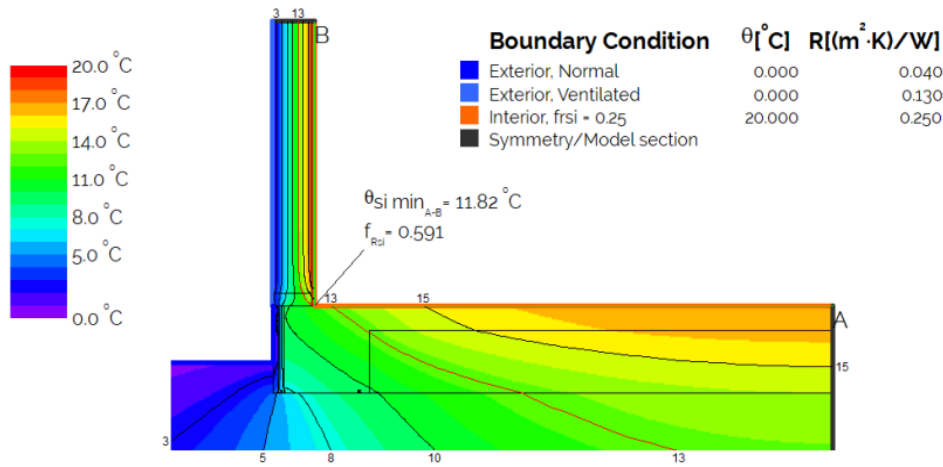

# QuickSet Ultra 305/00 with Polypod

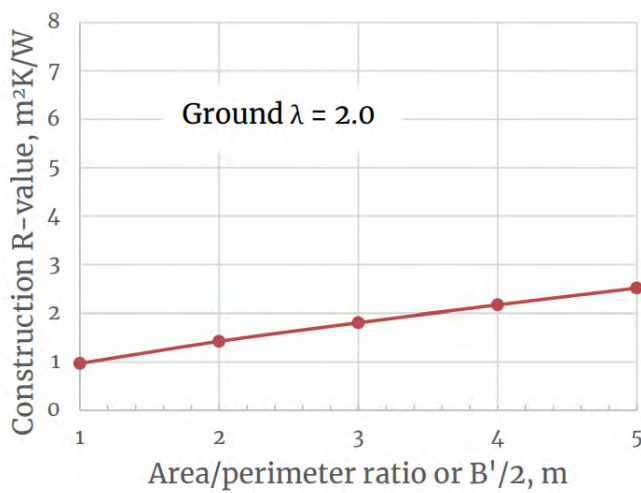
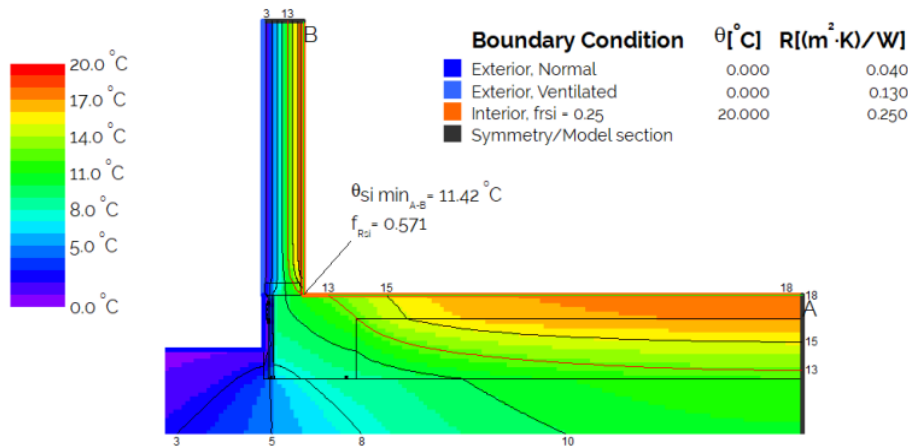

A/P, m	R-value, $\text{m}^2\text{K}/\text{W}$
1	0.97
1.6	1.24
1.8	1.33
2	1.42
2.2	1.50
2.4	1.58
2.6	1.65
2.8	1.73
3	1.81
3.2	1.88
3.4	1.95
3.6	2.02
3.8	2.10
4	2.17
5	2.51

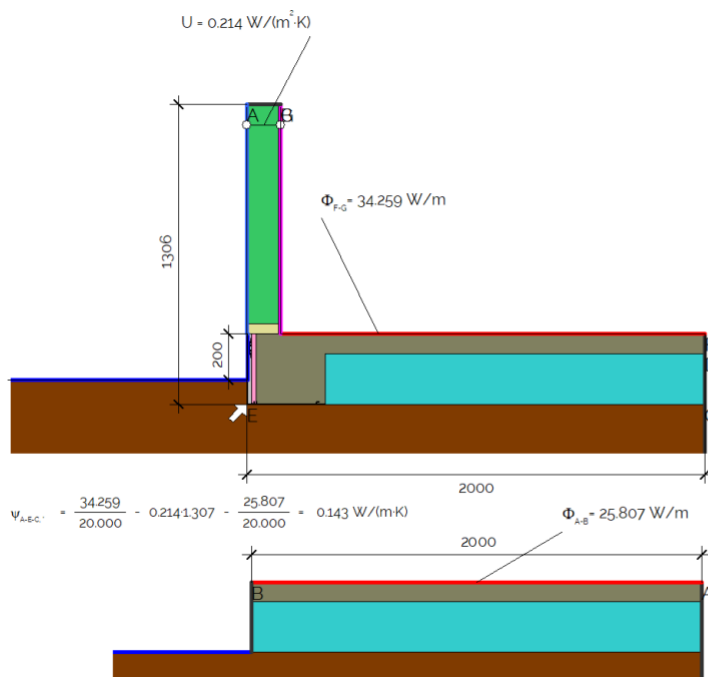

Boundary Condition	$\theta [^{\circ}\text{C}]$	$R[(\text{m}^2 \cdot \text{K})/\text{W}]$
Exterior, Normal	0.000	0.040
Exterior, Ventilated	0.000	0.130
Interior, heat flux, downwards	20.000	0.170
Interior, normal, horizontal	20.000	0.130
Symmetry/Model section		

  

Material	$\lambda[\text{W}/(\text{m} \cdot \text{K})]$
Aluminium	160.000
Concrete	2.000
Ground	2.000
PVC Foam board	0.100
Plasterboard	0.250
Polypropylene	0.220
Timber (Softwood)	0.130
WFPgxg-0.038/220/1100/SOIL	0.407
Wall insulation	0.032
XPSinsul_L0.028	0.028
Unventilated air cavity *	
* Simplified approach	

# QuickSet Ultra 305/25 with QPOD

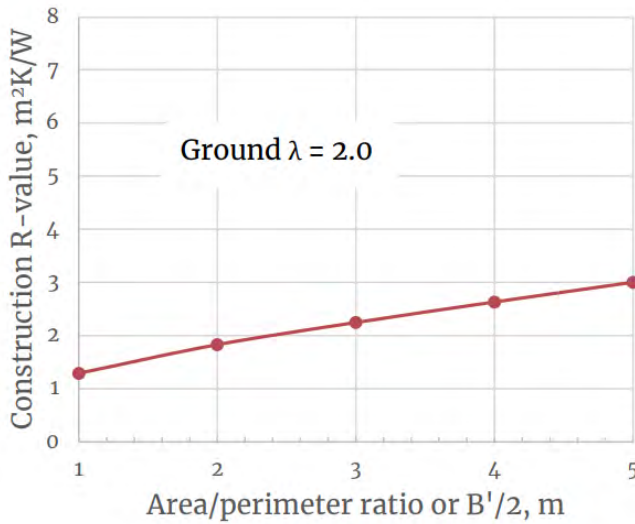
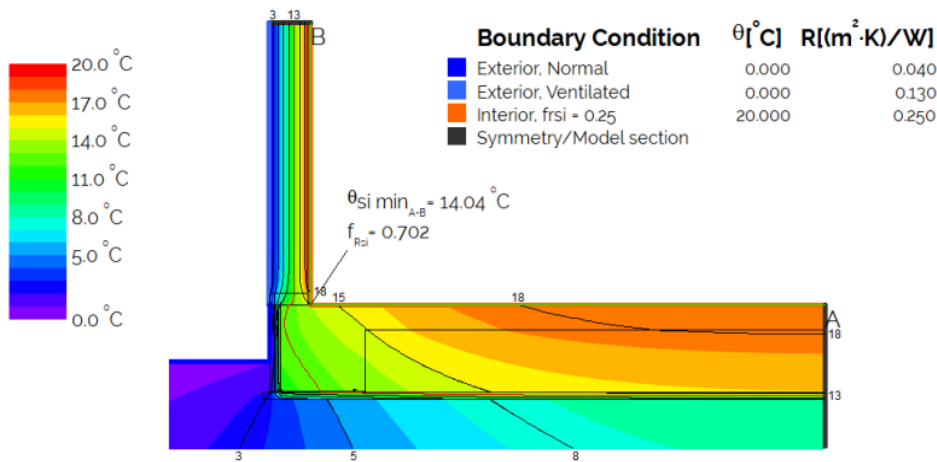

A/P, m	R-value, $\text{m}^2\text{K}/\text{W}$
1	1.29
1.6	1.61
1.8	1.72
2	1.83
2.2	1.91
2.4	2.00
2.6	2.08
2.8	2.16
3	2.25
3.2	2.32
3.4	2.40
3.6	2.48
3.8	2.55
4	2.63
5	3.00

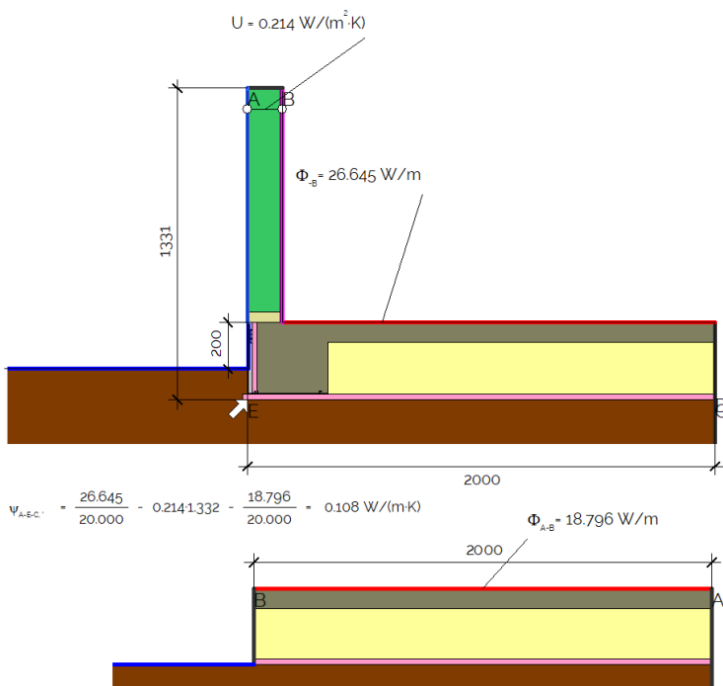

Boundary Condition	$\theta [^{\circ}\text{C}]$	$R[(\text{m}^2 \cdot \text{K})/\text{W}]$
Exterior, Normal	0.000	0.040
Exterior, Ventilated	0.000	0.130
Interior, heat flux, downwards	20.000	0.170
Interior, normal, horizontal	20.000	0.130
Symmetry/Model section		

  

Material	$\lambda[\text{W}/(\text{m} \cdot \text{K})]$
Aluminium	160.000
Concrete	2.000
Ground	2.000
PVC Foam board	0.100
Plasterboard	0.250
Polypropylene	0.220
QPod_4open	1.050
Timber (Softwood)	0.130
Wall insulation	0.032
XPSinsul_L0.028	0.028
Unventilated air cavity	
* Simplified approach	

# QuickSet Ultra 305/25 with Polypod

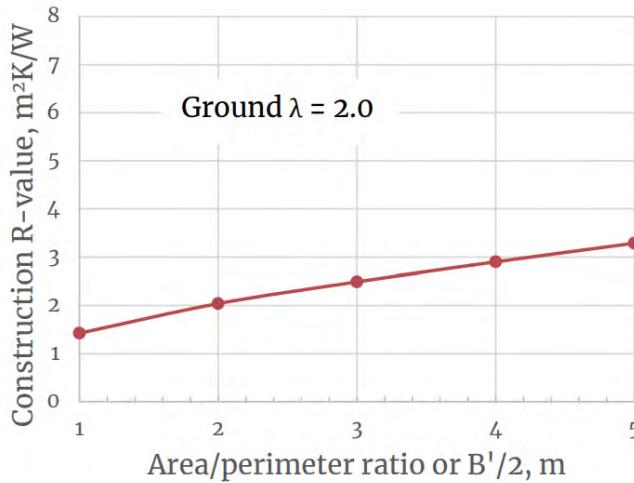
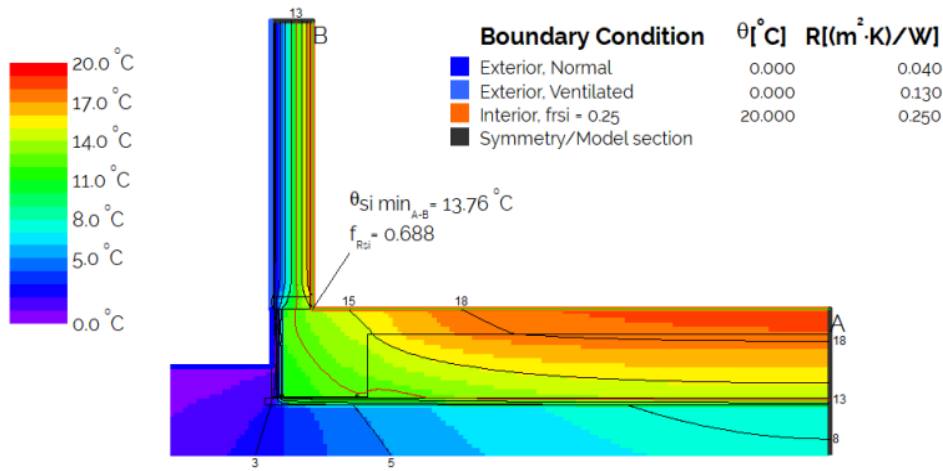

A/P, m	R-value, m²K/W
1	1.42
1.6	1.79
1.8	1.92
2	2.04
2.2	2.13
2.4	2.22
2.6	2.31
2.8	2.40
3	2.49
3.2	2.57
3.4	2.65
3.6	2.74
3.8	2.82
4	2.90
5	3.29

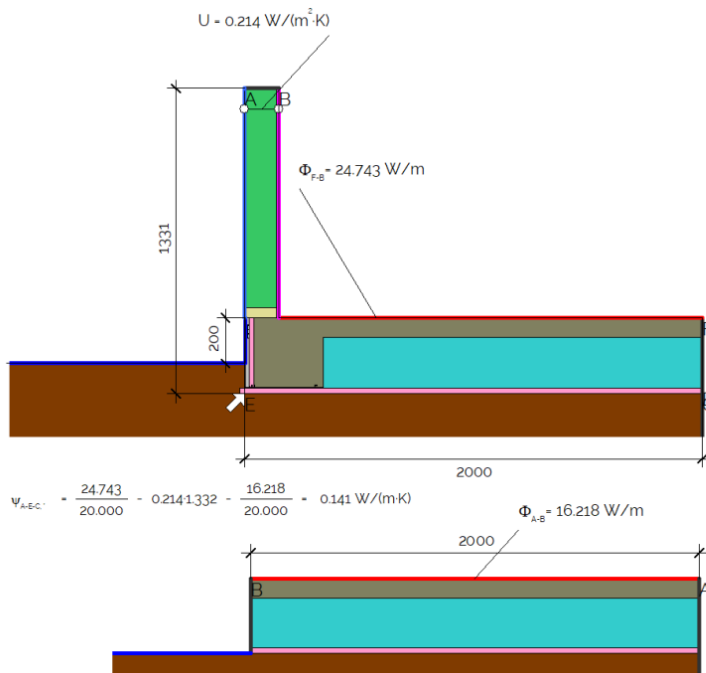

Boundary Condition	θ [°C]	R [(m²·K)/W]
Exterior, Normal	0.000	0.040
Exterior, Ventilated	0.000	0.130
Interior, heat flux, downwards	20.000	0.170
Interior, normal, horizontal	20.000	0.130
Symmetry/Model section		

  

Material	λ [W/(m·K)]
Aluminium	160.000
Concrete	2.000
Ground	2.000
PVC Foam board	0.100
Plasterboard	0.250
Polypropylene	0.220
Timber (Softwood)	0.130
WFPgxg-0.038/220/1100/SOIL	0.407
Wall insulation	0.032
XPSinsuL_0.028	0.028
Unventilated air cavity	
* Simplified approach	

# QuickSet Ultra 305/50 with QPOD

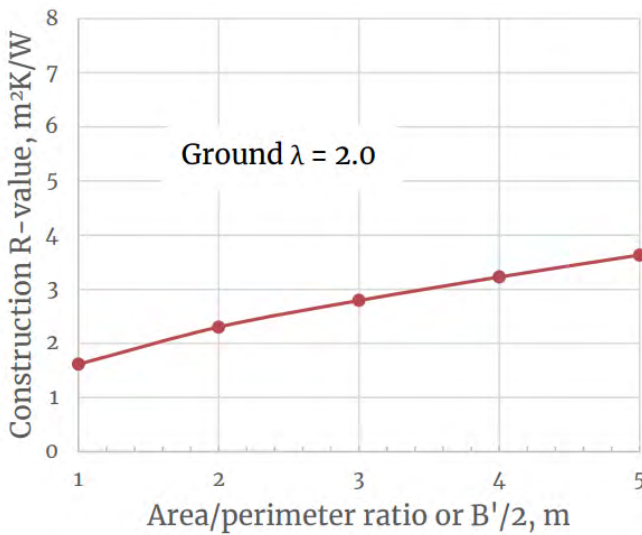
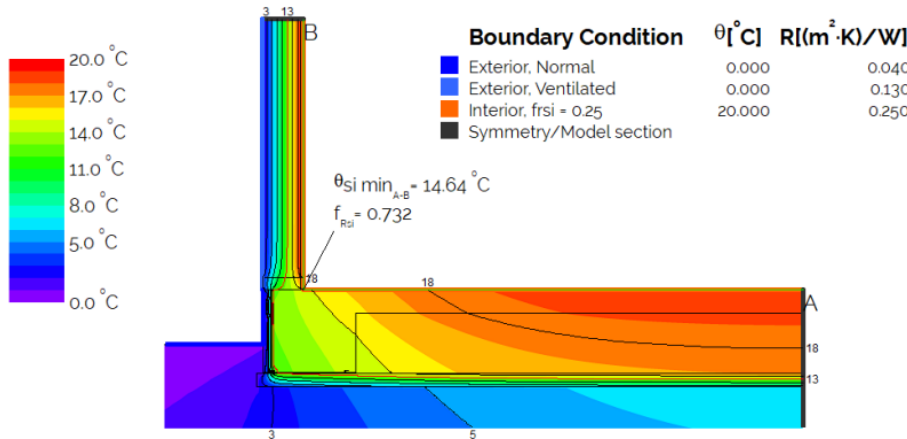

A/P, m	R-value, m²K/W
1	1.62
1.6	2.03
1.8	2.17
2	2.30
2.2	2.40
2.4	2.50
2.6	2.60
2.8	2.69
3	2.79
3.2	2.88
3.4	2.97
3.6	3.05
3.8	3.14
4	3.23
5	3.63

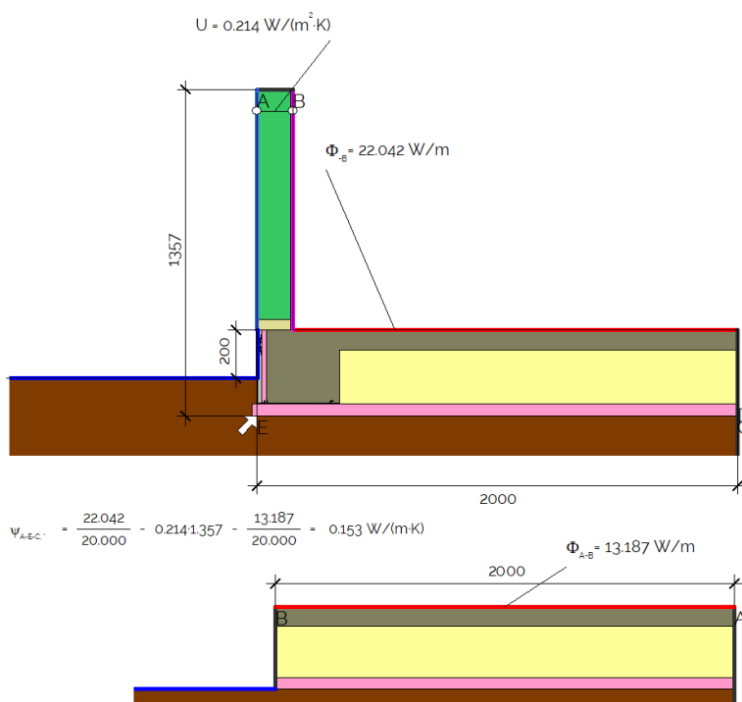

Boundary Condition	$\theta [^{\circ}\text{C}]$	$R[(\text{m}^2\cdot\text{K})/\text{W}]$
Exterior, Normal	0.000	0.040
Exterior, Ventilated	0.000	0.130
Interior, heat flux, downwards	20.000	0.170
Interior, normal, horizontal	20.000	0.130
Symmetry/Model section		

Material	$\lambda[\text{W}/(\text{m}\cdot\text{K})]$
Aluminium	160.000
Concrete	2.000
Ground	2.000
PVC Foam board	0.100
Plasterboard	0.250
Polypropylene	0.220
QPod_4open	1.050
Timber (Softwood)	0.130
Wall insulation	0.032
XPSinsul_L0.028	0.028
Unventilated air cavity	
* Simplified approach	

$$\psi_{AEC} = \frac{22.042}{20.000} - 0.214 \cdot 1.357 - \frac{13.187}{20.000} = 0.153 \text{ W/(m}\cdot\text{K)}$$

# QuickSet Ultra 305/50 with Polypod

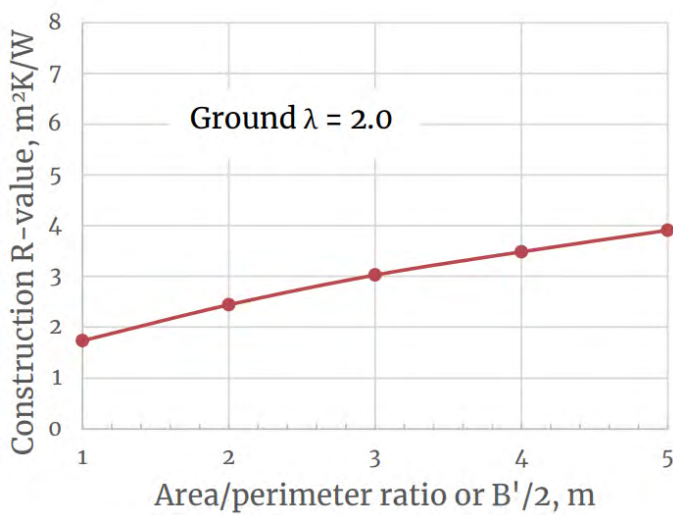
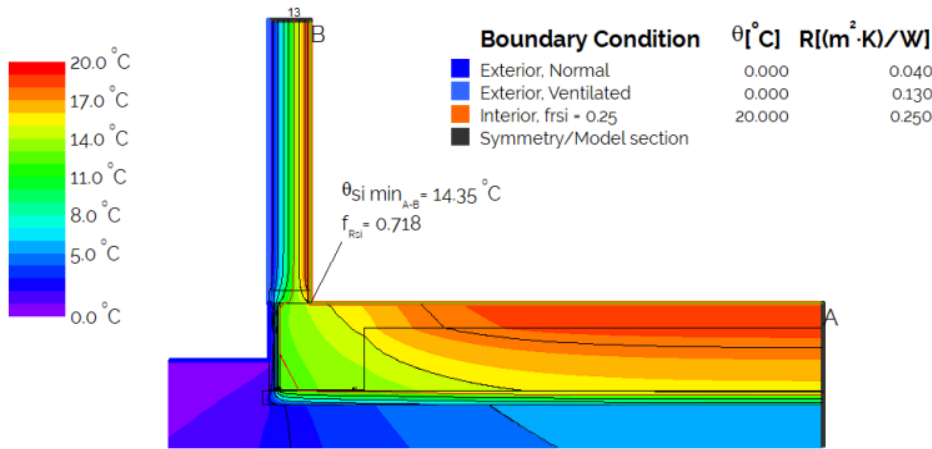

A/P, m	R-value, m²K/W
1	1.73
1.6	2.15
1.8	2.30
2	2.44
2.2	2.56
2.4	2.67
2.6	2.79
2.8	2.91
3	3.02
3.2	3.12
3.4	3.21
3.6	3.30
3.8	3.39
4	3.48
5	3.91

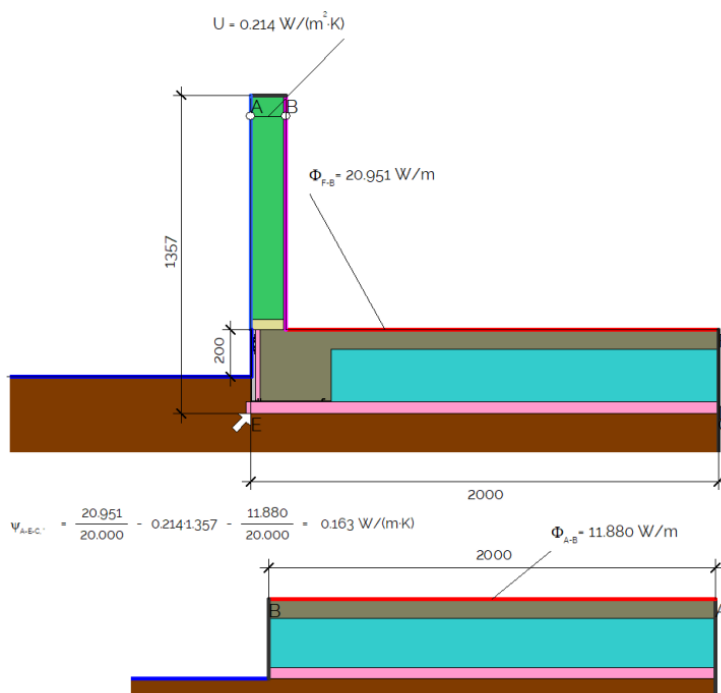

Boundary Condition	$\theta [^{\circ}\text{C}]$	$R [(\text{m}^2 \cdot \text{K})/\text{W}]$
Exterior, Normal	0.000	0.040
Exterior, Ventilated	0.000	0.130
Interior, heat flux, downwards	20.000	0.170
Interior, normal, horizontal	20.000	0.130
Symmetry/Model section		

  

Material	$\lambda [W/(m \cdot K)]$
Aluminium	160.000
Concrete	2.000
Ground	2.000
PVC Foam board	0.100
Plasterboard	0.250
Polypropylene	0.220
Timber (Softwood)	0.130
WFPgxg-0.038/220/1100/SOIL	0.407
Wall insulation	0.032
XPSinsul_Lo.028	0.028
Unventilated air cavity	
* Simplified approach	

$$U_{A-B-C} = \frac{20.951}{20.000} - 0.214 \cdot 1357 - \frac{11.880}{20.000} = 0.163 \text{ W/(m}^2\text{K)}$$

$$\Phi_{A-B} = 11.880 \text{ W/m}$$

# QuickSet Ultra 305/75 with QPOD

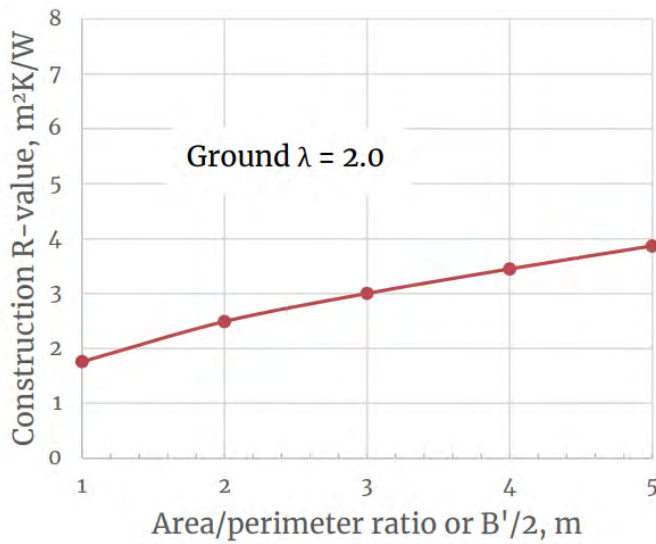
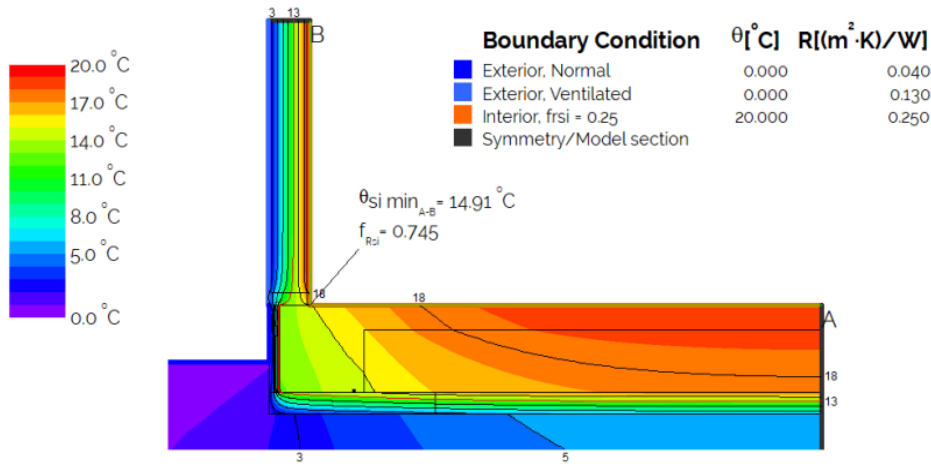

A/P, m	R-value, m²K/W
1	1.76
1.6	2.20
1.8	2.35
2	2.49
2.2	2.59
2.4	2.70
2.6	2.80
2.8	2.90
3	3.00
3.2	3.09
3.4	3.18
3.6	3.27
3.8	3.36
4	3.45
5	3.87

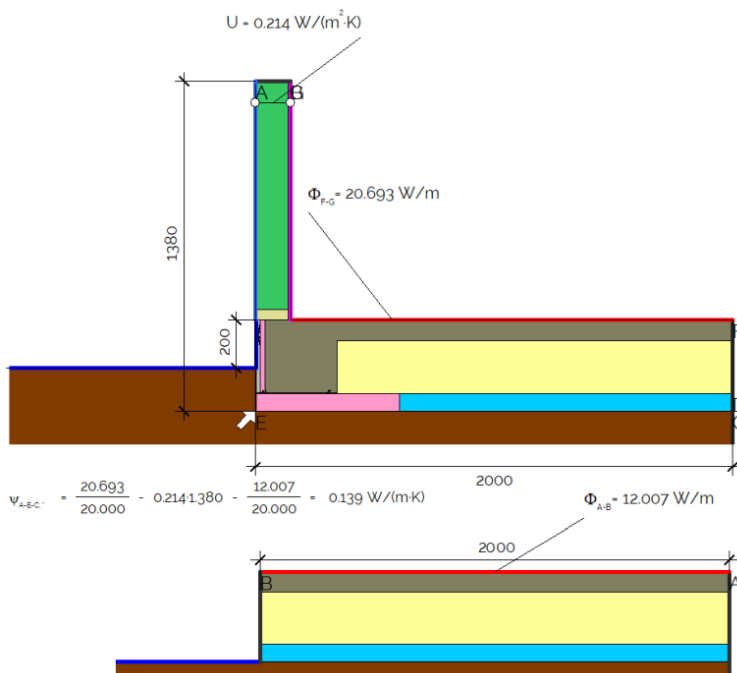

Boundary Condition	$\theta [^{\circ}\text{C}]$	$R [(\text{m}^2\cdot\text{K})/\text{W}]$
Exterior, Normal	0.000	0.040
Exterior, Ventilated	0.000	0.130
Interior, heat flux, downwards	20.000	0.170
Interior, normal, horizontal	20.000	0.130
Symmetry/Model section		

  

Material	$\lambda [W/(m\cdot K)]$
Aluminium	160.000
Concrete	2.000
EPS H	0.036
Ground	2.000
PVC Foam board	0.100
Plasterboard	0.250
Polypropylene	0.220
QPod_4open	1.050
Timber (Softwood)	0.130
Wall insulation	0.032
XPSinsu_L_0.028	0.028
Unventilated air cavity *	
* Simplified approach	

# QuickSet Ultra 305/75 with Polypod

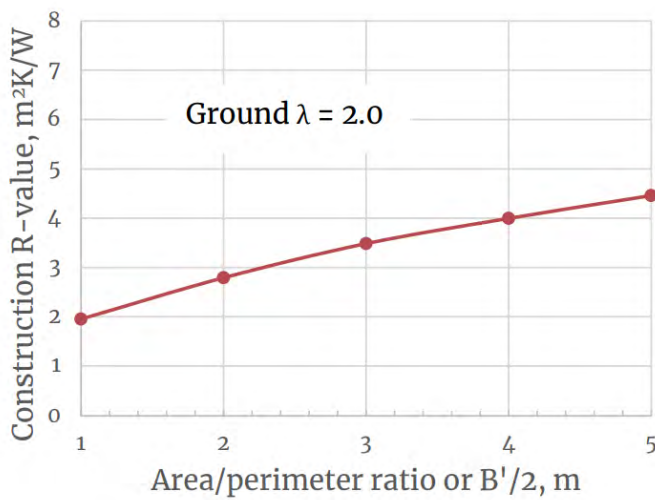
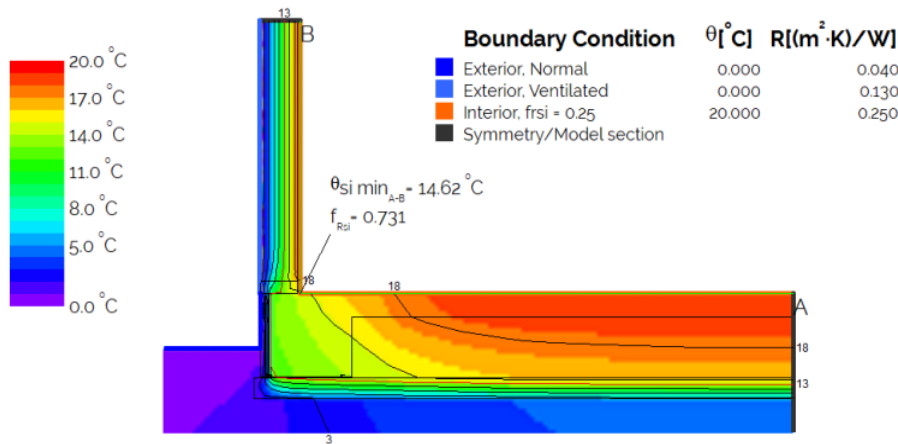

A/P, m	R-value, m²K/W
1	1.95
1.6	2.46
1.8	2.62
2	2.79
2.2	2.93
2.4	3.07
2.6	3.21
2.8	3.34
3	3.48
3.2	3.59
3.4	3.69
3.6	3.79
3.8	3.89
4	4.00
5	4.46

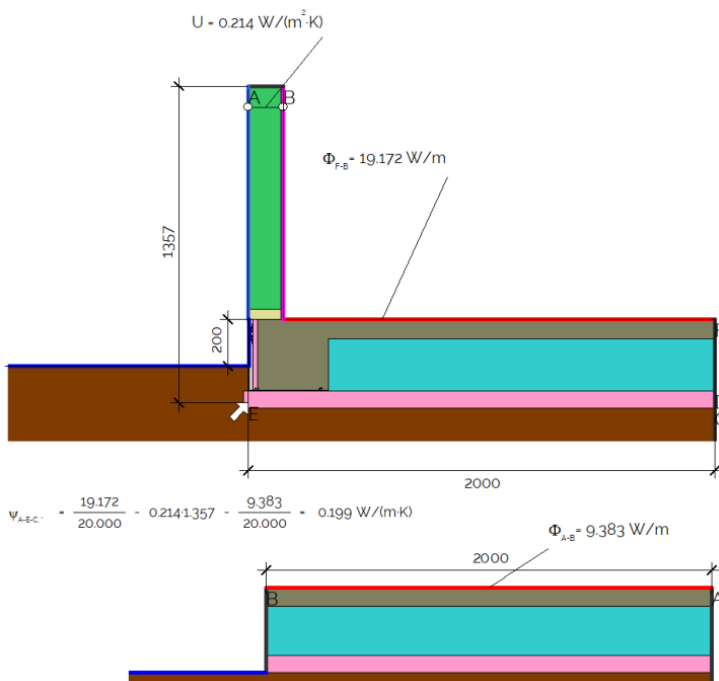

Boundary Condition	$\theta [^{\circ}\text{C}]$	$R [(\text{m}^2 \cdot \text{K})/\text{W}]$
Exterior, Normal	0.000	0.040
Exterior, Ventilated	0.000	0.130
Interior, heat flux, downwards	20.000	0.170
Interior, normal, horizontal	20.000	0.130
Symmetry/Model section		

Material	$\lambda [W / (\text{m} \cdot \text{K})]$
Aluminium	160.000
Concrete	2.000
Ground	2.000
PVC Foam board	0.100
Plasterboard	0.250
Polypropylene	0.220
Timber (Softwood)	0.130
WFP9x9-0.038/220/1100/SOIL	0.407
Wall insulation	0.032
XPSinsuL_L0.028	0.028
Unventilated air cavity *	
* Simplified approach	



# QuickSet Ultra 305/100 with Polypod

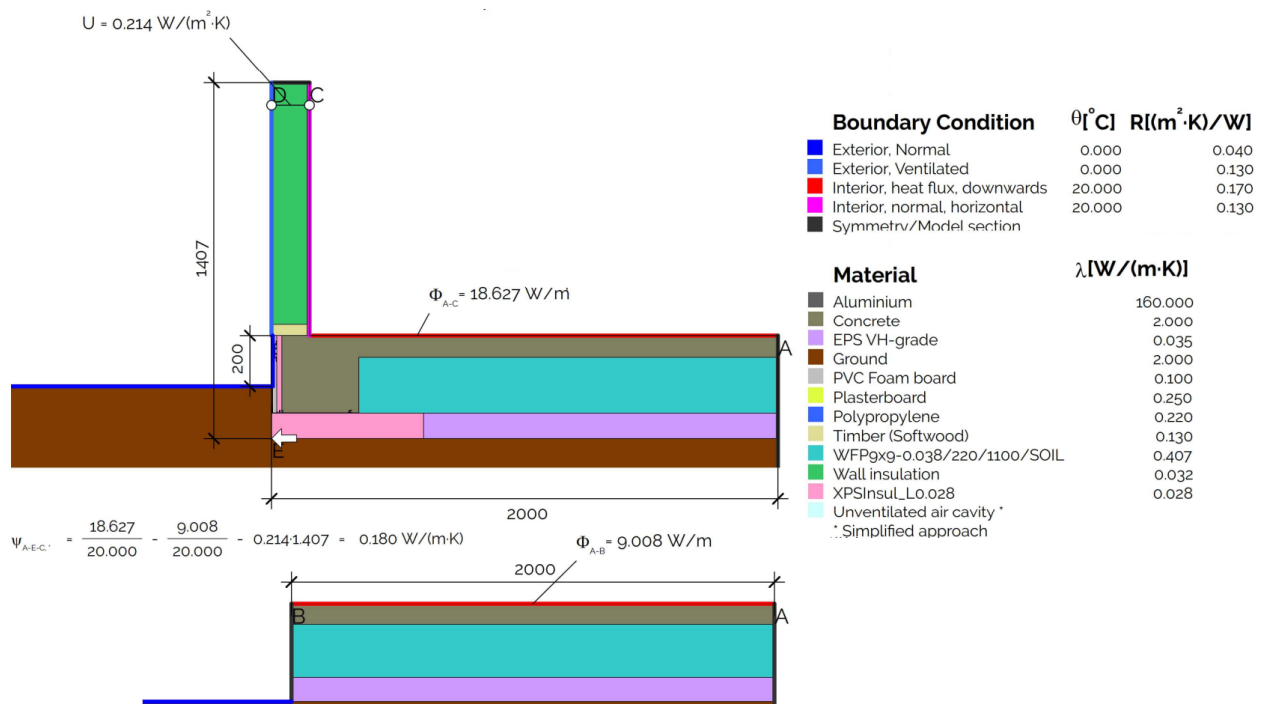
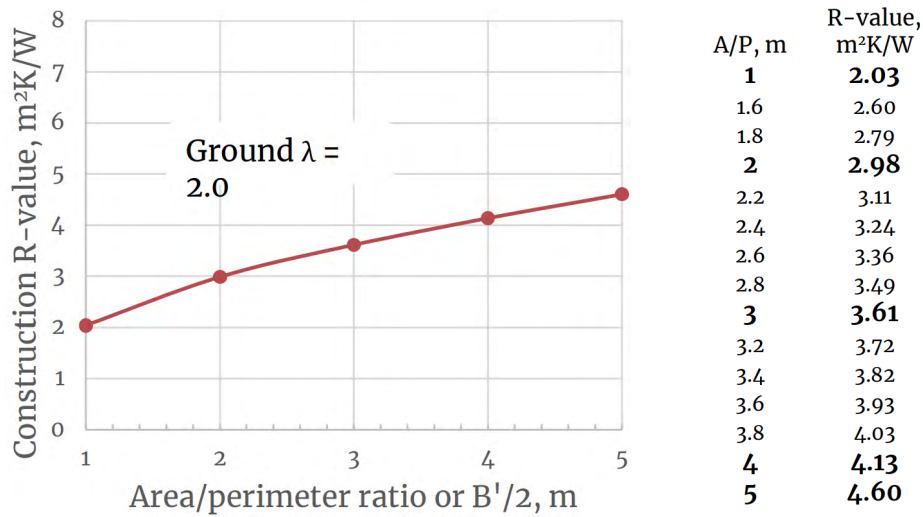
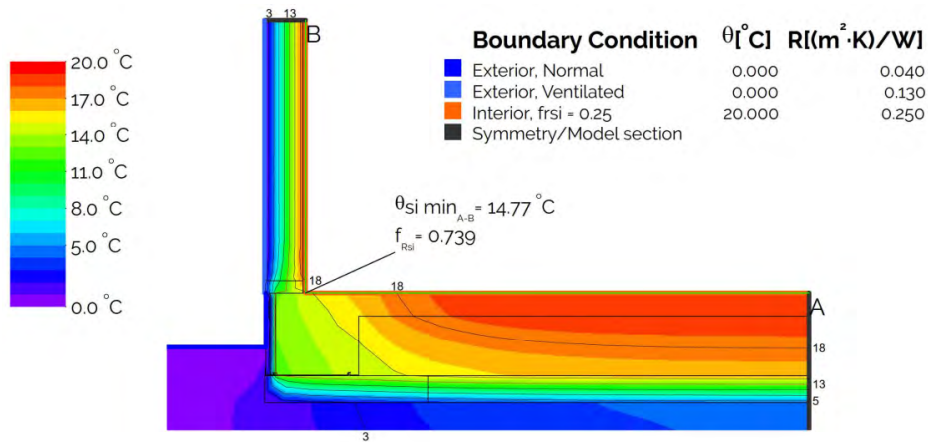

# QuickSet Ultra 305/150 (Continuous SlabX200) with QPOD

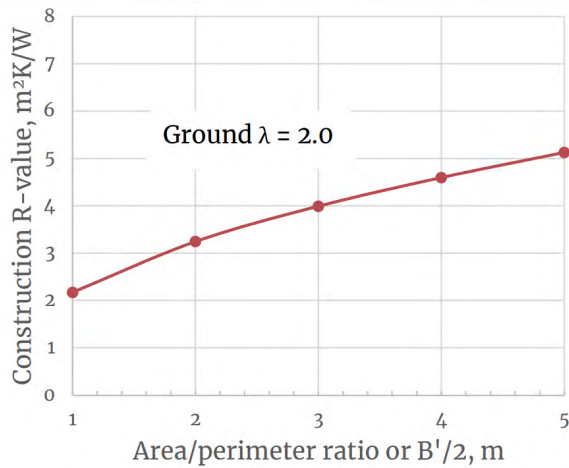
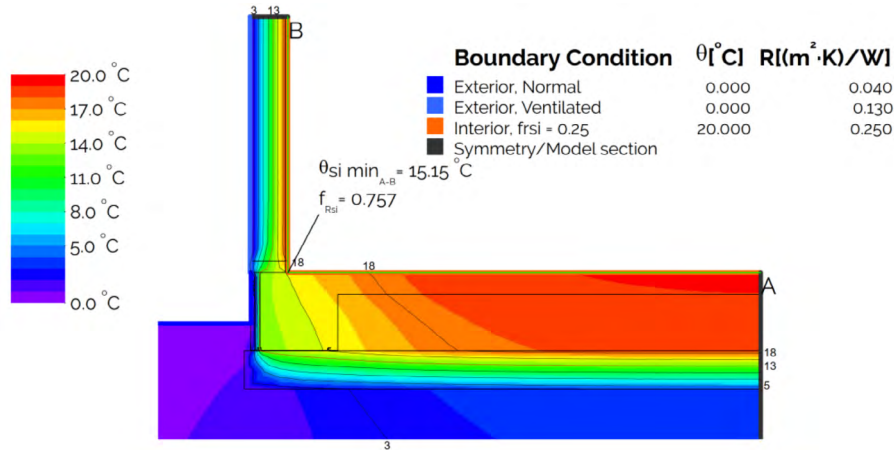

A/P, m	R-value, $m^2K/W$
1	2.17
1.6	2.81
1.8	3.03
2	3.24
2.2	3.39
2.4	3.54
2.6	3.69
2.8	3.84
3	3.99
3.2	4.11
3.4	4.23
3.6	4.35
3.8	4.47
4	4.60
5	5.13

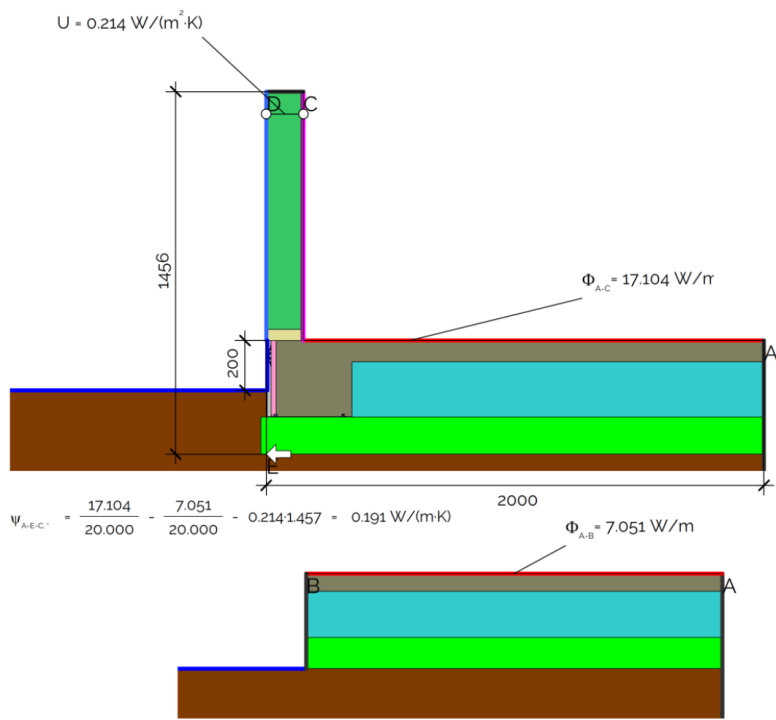

Boundary Condition	θ [°C]	R [(m²·K)/W]
Exterior, Normal	0.000	0.040
Exterior, Ventilated	0.000	0.130
Interior, heat flux, downwards	20.000	0.170
Interior, normal, horizontal	20.000	0.130
Symmetry/Model section		

  

Material	λ [W/(m·K)]
SlabX200	1.052
Aluminium	160.000
Concrete	2.000
Ground	2.000
PVC Foam board	0.100
Plasterboard	0.250
Polypropylene	0.220
SlabX200	0.034
Timber (Softwood)	0.130
Wall insulation	0.032
XPSinsul_Lo.028	0.028
Unventilated air cavity *	
* Simplified approach	

# QuickSet Ultra 305/150 (Continuous SlabX200) with Polypod

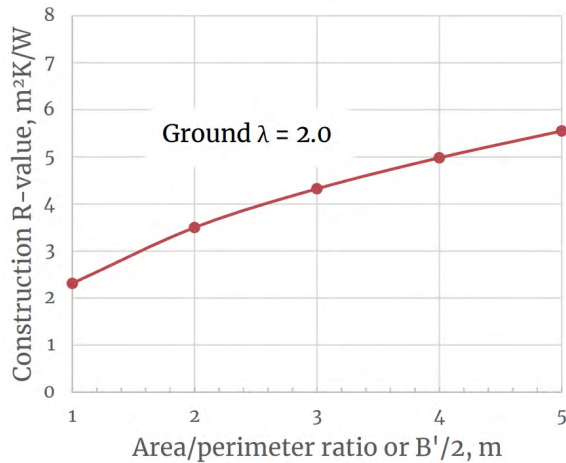
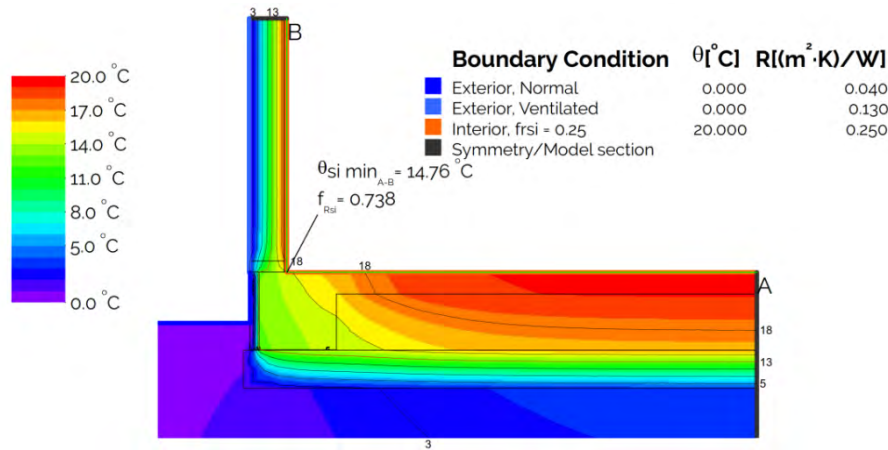

A/P, m	R-value, m²K/W
1	2.31
1.6	3.02
1.8	3.26
2	3.50
2.2	3.66
2.4	3.83
2.6	3.99
2.8	4.16
3	4.32
3.2	4.45
3.4	4.59
3.6	4.72
3.8	4.85
4	4.98
5	5.55

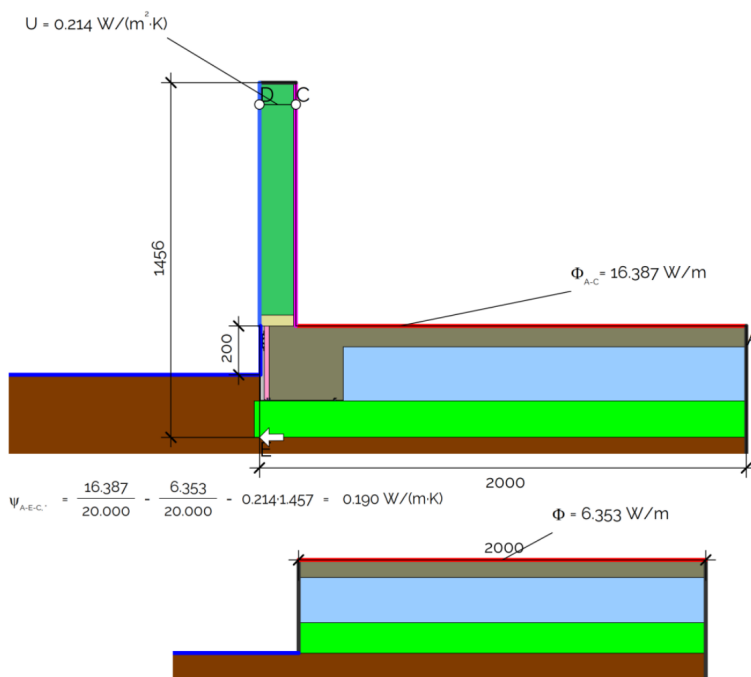

$$\psi_{A-C} = \frac{16.387}{20.000} - \frac{6.353}{20.000} - 0.214 \cdot 1457 = 0.190 \text{ W/(mK)}$$

Boundary Condition	$\theta$ [°C]	R [(m²·K)/W]
Exterior, Normal	0.000	0.040
Exterior, Ventilated	0.000	0.130
Interior, heat flux, downwards	20.000	0.170
Interior, normal, horizontal	20.000	0.130
Symmetry/Model section		

Material	$\lambda$ [W/(m·K)]
SlabX200	0.266
Aluminium	160.000
Concrete	2.000
Ground	2.000
PVC Foam board	0.100
Plasterboard	0.250
Polypropylene	0.220
SlabX200	0.034
Timber (Softwood)	0.130
Wall insulation	0.032
XPSinsul_Lo.028	0.028
Unventilated air cavity	0.028

\* Simplified approach

# QuickSet Rebate

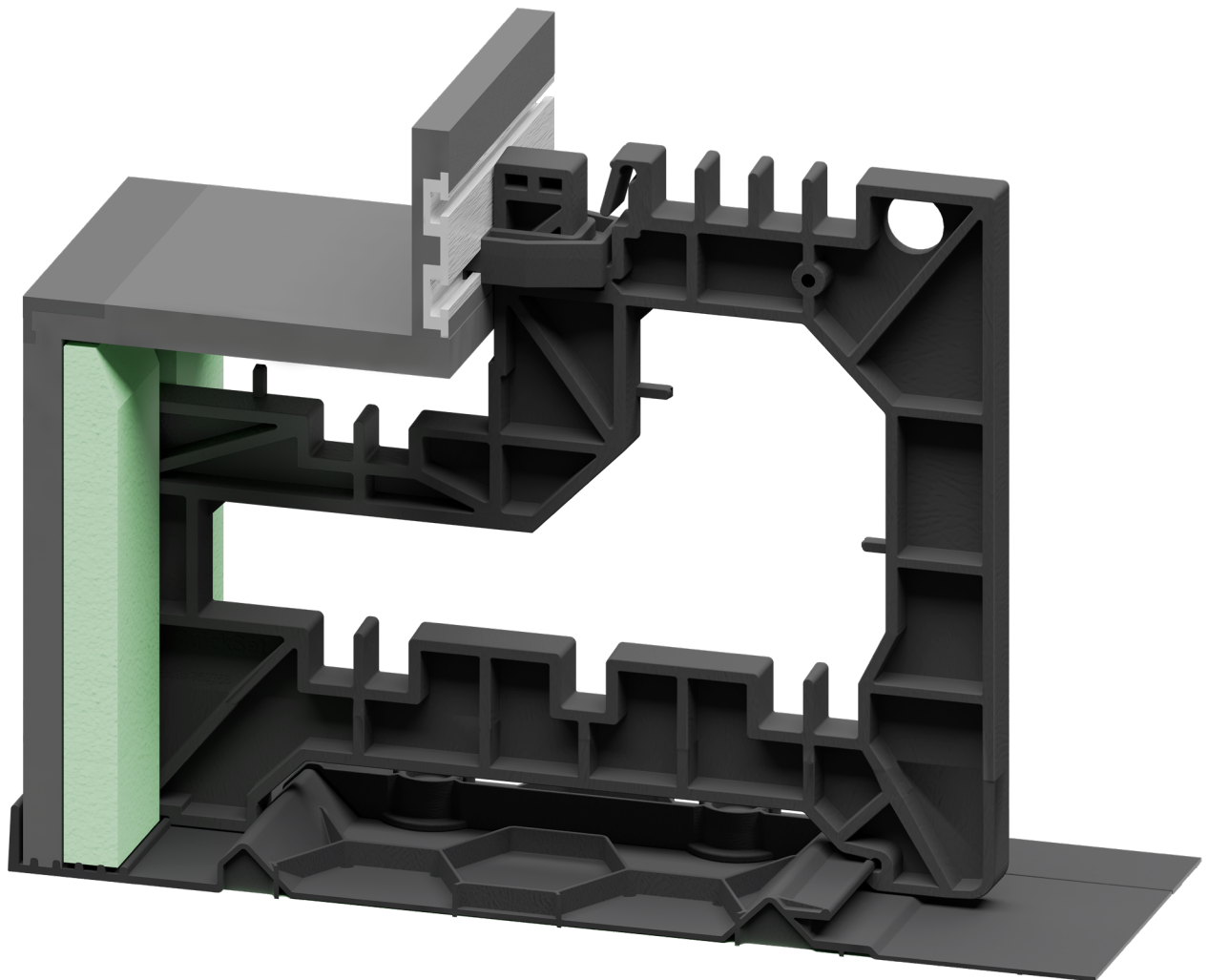

- Height options of 305, 320, 385, or 400mm;
- Suitable for 220mm and 300mm pod systems;
- Compatible with 90mm, 140mm framing, and above.

# QuickSet Rebate 120/305/00 with QPOD

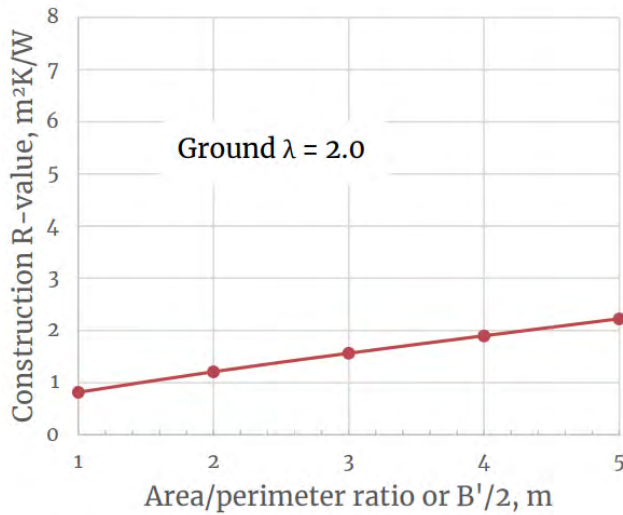
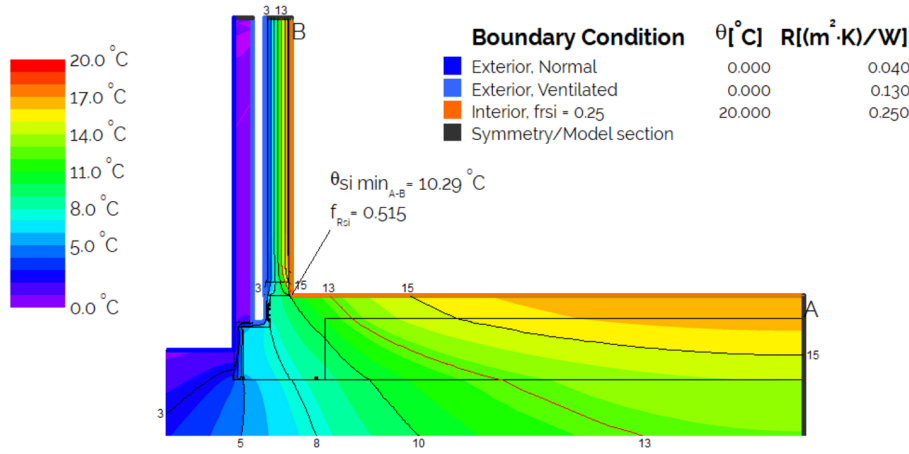

A/P, m	R-value, m²K/W
1	0.81
1.6	1.05
1.8	1.13
2	1.21
2.2	1.28
2.4	1.35
2.6	1.42
2.8	1.49
3	1.56
3.2	1.63
3.4	1.70
3.6	1.76
3.8	1.83
4	1.90
5	2.22

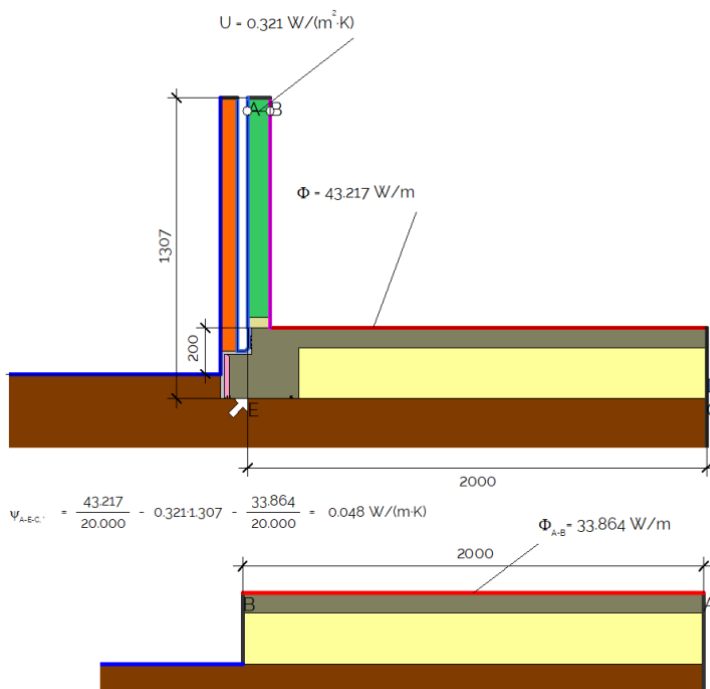

Boundary Condition	θ [°C]	R [(m²·K)/W]
Exterior, Normal	0.000	0.040
Exterior, Ventilated	0.000	0.130
Interior, heat flux, downwards	20.000	0.170
Interior, normal, horizontal	20.000	0.130
Symmetry/Model section		

  

Material	λ [W/(m·K)]
Aluminium	160.000
Brick	0.350
Concrete	2.000
Ground	2.000
PVC Foam board	0.100
Plasterboard	0.250
Polypropylene	0.220
QPod_4open	1.050
Timber (Softwood)	0.130
Wall insulation	0.032
XPSinsul_L0.028	0.028

# QuickSet Rebate 120/305/00 with Polypod

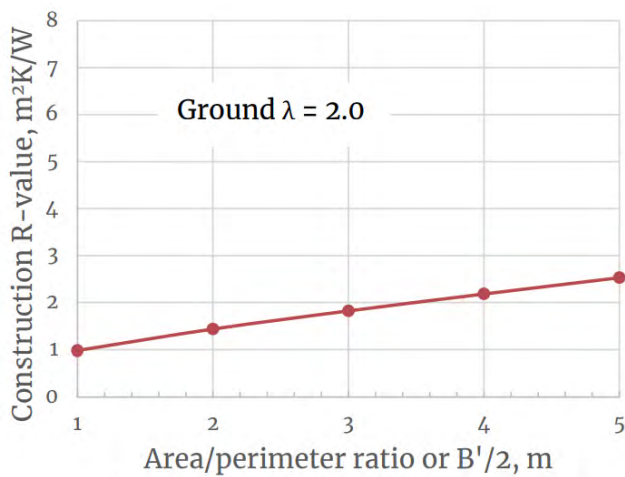
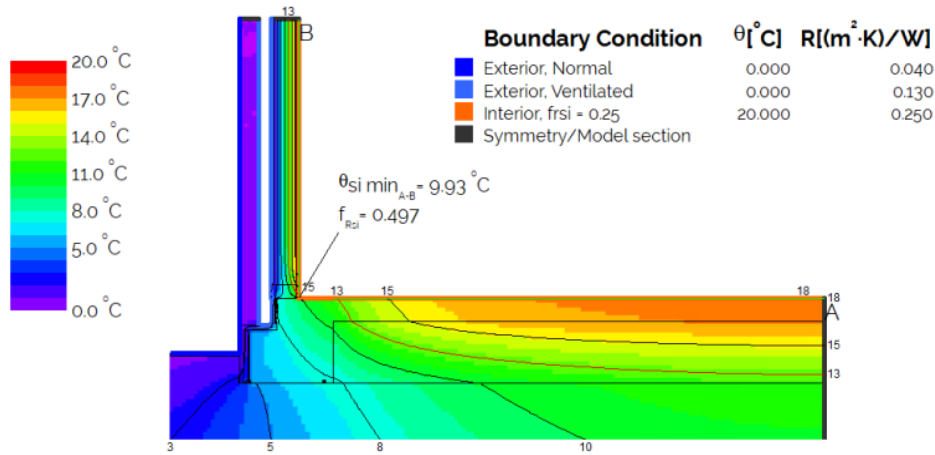

A/P, m	R-value, m²K/W
1	0.98
1.6	1.25
1.8	1.35
2	1.44
2.2	1.51
2.4	1.59
2.6	1.67
2.8	1.75
3	1.82
3.2	1.89
3.4	1.97
3.6	2.04
3.8	2.11
4	2.18
5	2.53

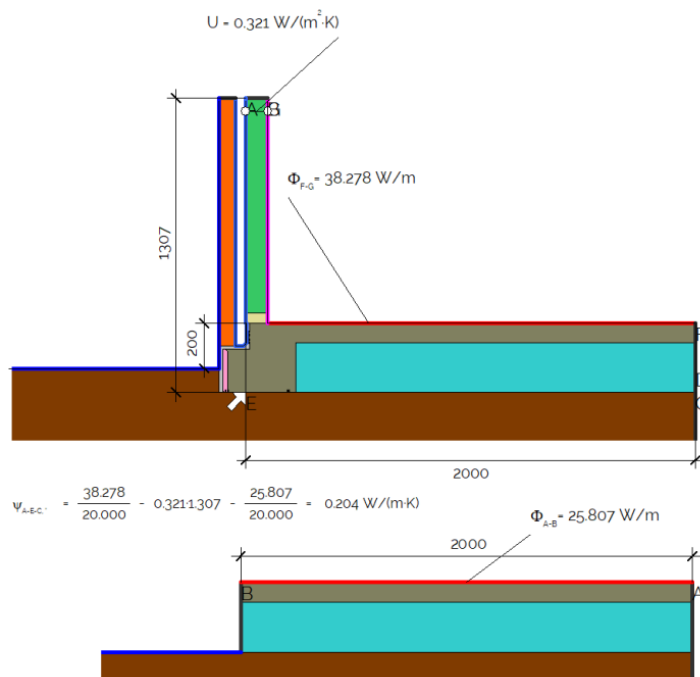

Boundary Condition	θ [°C]	R [(m²·K)/W]
Exterior, Normal	0.000	0.040
Exterior, Ventilated	0.000	0.130
Interior, heat flux, downwards	20.000	0.170
Interior, normal, horizontal	20.000	0.130
Symmetry/Model section		

  

Material	λ [W/(m·K)]
Aluminium	160.000
Brick	0.350
Concrete	2.000
Ground	2.000
PVC Foam board	0.100
Plasterboard	0.250
Polypropylene	0.220
Timber (Softwood)	0.130
WFFPg9-0.038/220/1100/SOIL	0.407
Wall insulation	0.032
XPSinsu_L0.028	0.028

# QuickSet Rebate 120/305/25 with QPOD

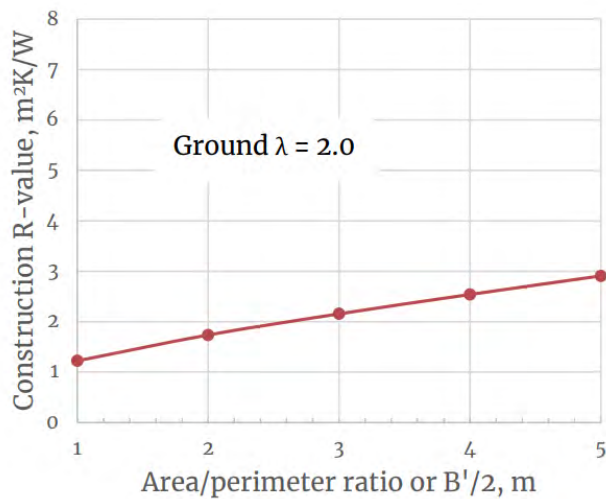
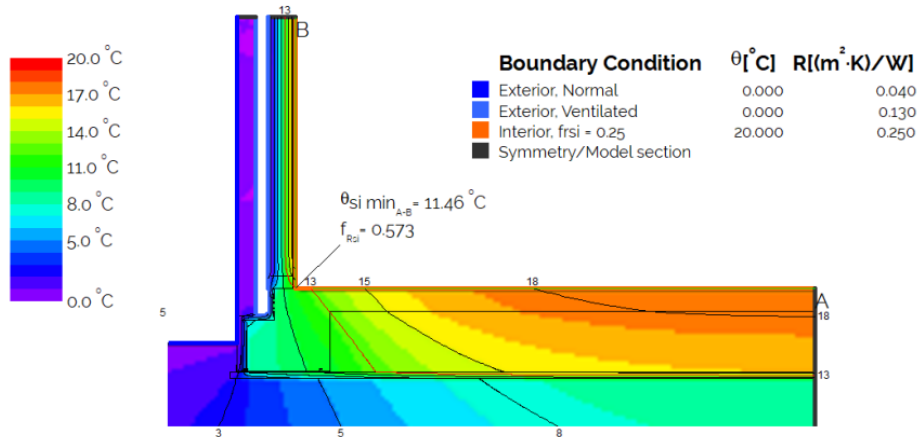

A/P, m	R-value, m²K/W
1	1.22
1.6	1.53
1.8	1.63
2	1.74
2.2	1.82
2.4	1.90
2.6	1.99
2.8	2.07
3	2.16
3.2	2.23
3.4	2.31
3.6	2.39
3.8	2.46
4	2.54
5	2.91

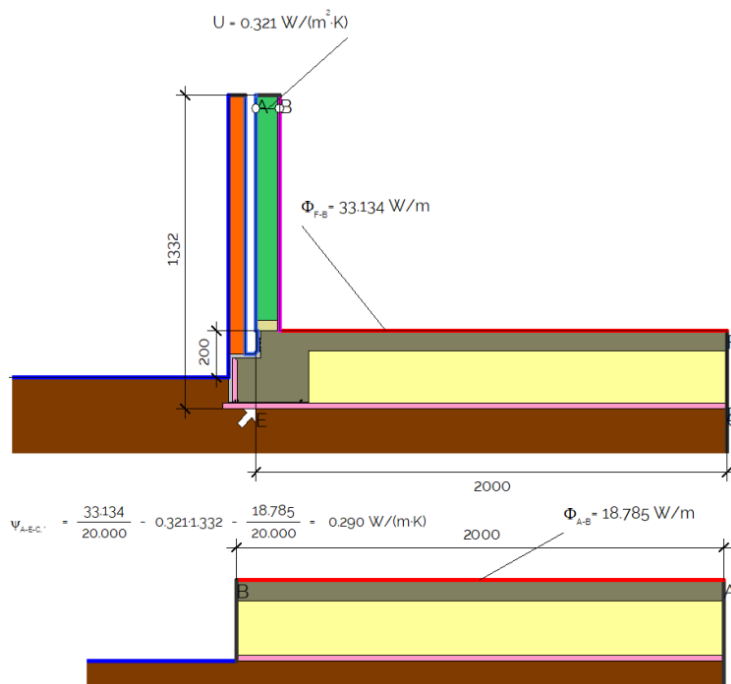

Boundary Condition	θ [°C]	R [(m²·K)/W]
Exterior, Normal	0.000	0.040
Exterior, Ventilated	0.000	0.130
Interior, heat flux, downwards	20.000	0.170
Interior, normal, horizontal	20.000	0.130
Symmetry/Model section		

  

Material	λ [W/(m·K)]
Aluminium	160.000
Brick	0.350
Concrete	2.000
Ground	2.000
PVC Foam board	0.100
Plasterboard	0.250
Polypropylene	0.220
QPod_4open	1.050
Timber (Softwood)	0.130
Wall insulation	0.032
XPSinsul_L0.028	0.028

# QuickSet Rebate 120/305/25 with Polypod

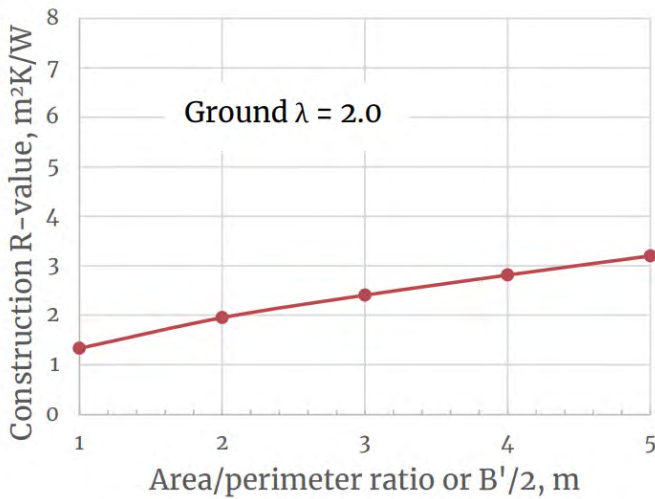
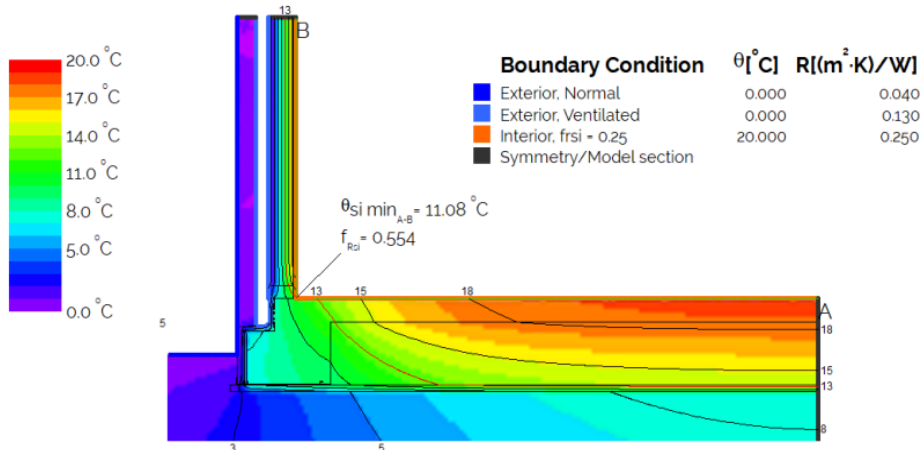

A/P, m	R-value, m²K/W
1	1.33
1.6	1.70
1.8	1.83
2	1.95
2.2	2.04
2.4	2.13
2.6	2.22
2.8	2.31
3	2.40
3.2	2.49
3.4	2.57
3.6	2.65
3.8	2.73
4	2.81
5	3.20

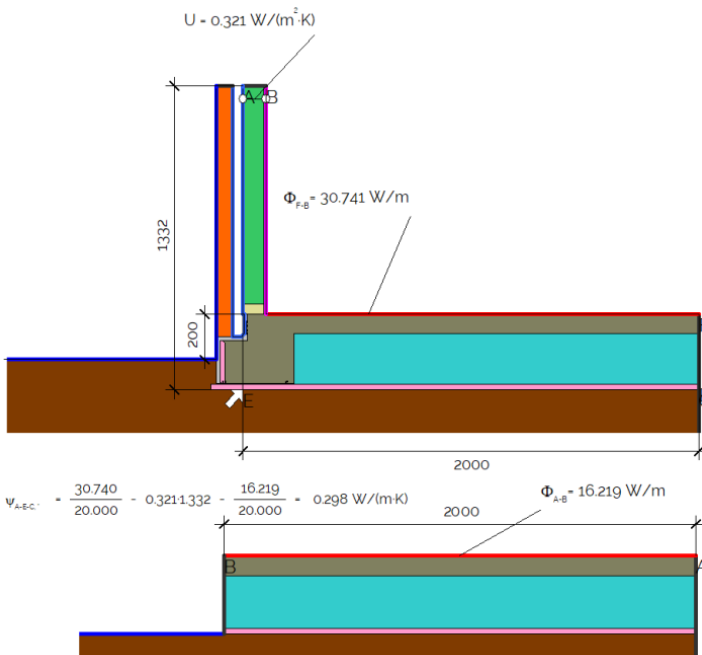

Boundary Condition	θ [°C]	R [(m²·K)/W]
Exterior, Normal	0.000	0.040
Exterior, Ventilated	0.000	0.130
Interior, heat flux, downwards	20.000	0.170
Interior, normal, horizontal	20.000	0.130
Symmetry/Model section		

Material	λ [W/(m·K)]
Aluminium	160.000
Brick	0.350
Concrete	2.000
Ground	2.000
PVC Foam board	0.100
Plasterboard	0.250
Polypropylene	0.220
Timber (Softwood)	0.130
WFPg9-0.038/220/1100/SOIL	0.407
Wall insulation	0.032
XPSinsul_L.0.028	0.028



# QuickSet Rebate 120/305/50 with QPOD

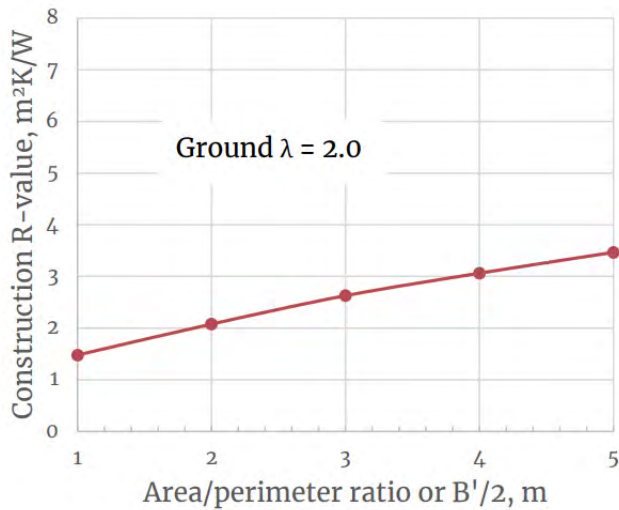
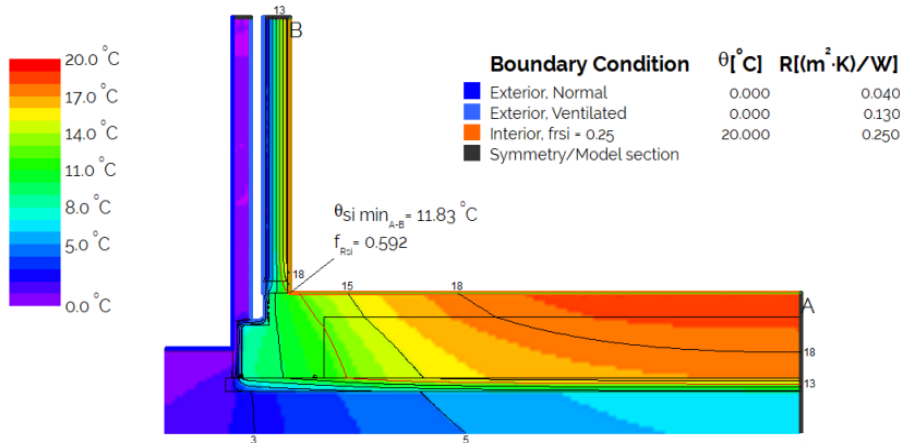

A/P, m	R-value, $\text{m}^2\text{K}/\text{W}$
1	1.48
1.6	1.84
1.8	1.96
2	2.08
2.2	2.19
2.4	2.30
2.6	2.41
2.8	2.52
3	2.63
3.2	2.71
3.4	2.80
3.6	2.89
3.8	2.98
4	3.06
5	3.47

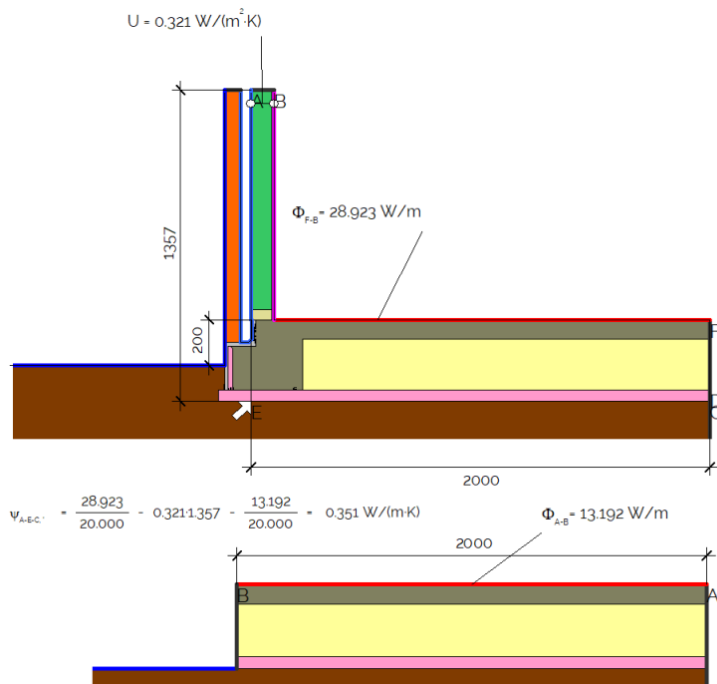

Boundary Condition	$\theta [^{\circ}\text{C}]$	$R[(\text{m}^2 \cdot \text{K})/\text{W}]$
Exterior, Normal	0.000	0.040
Exterior, Ventilated	0.000	0.130
Interior, heat flux, downwards	20.000	0.170
Interior, normal, horizontal	20.000	0.130
Symmetry/Model section		

  

Material	$\lambda[\text{W}/(\text{m} \cdot \text{K})]$
Aluminium	160.000
Brick	0.350
Concrete	2.000
Ground	2.000
PVC Foam board	0.100
Plasterboard	0.250
Polypropylene	0.220
QPod_4open	1.050
Timber (Softwood)	0.130
Wall insulation	0.032
XPSinsul_L0.028	0.028

# QuickSet Rebate 120/305/50 with Polypod

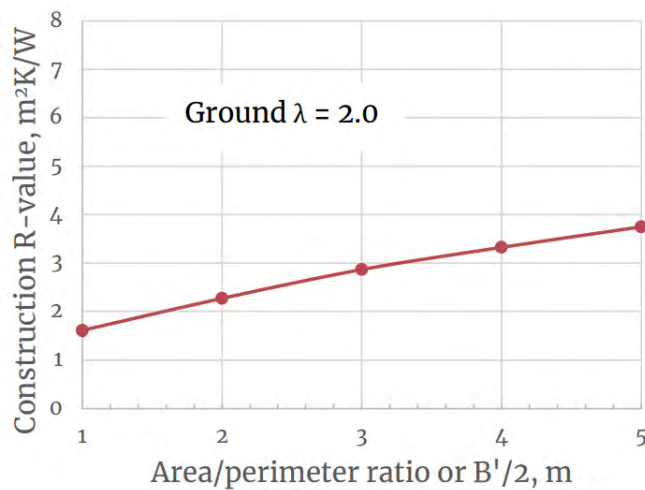
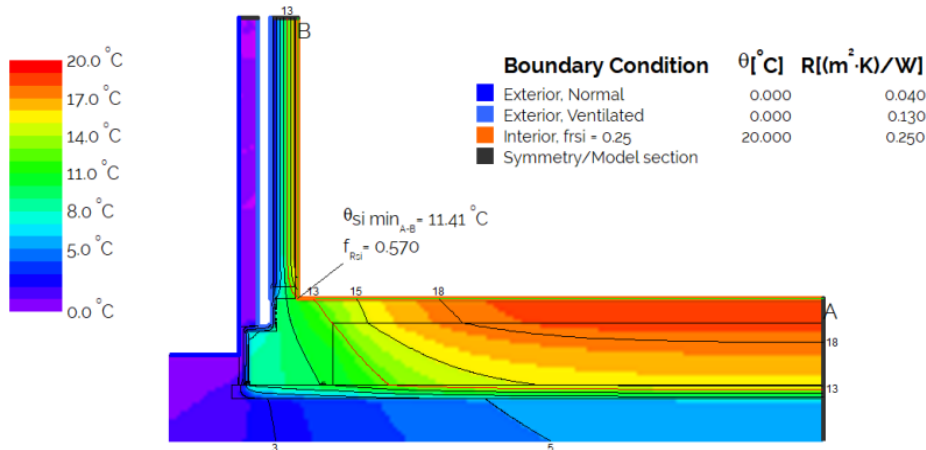

A/P, m	R-value, m²K/W
1	1.61
1.6	2.00
1.8	2.14
2	2.27
2.2	2.39
2.4	2.51
2.6	2.63
2.8	2.75
3	2.86
3.2	2.96
3.4	3.05
3.6	3.14
3.8	3.23
4	3.32
5	3.75

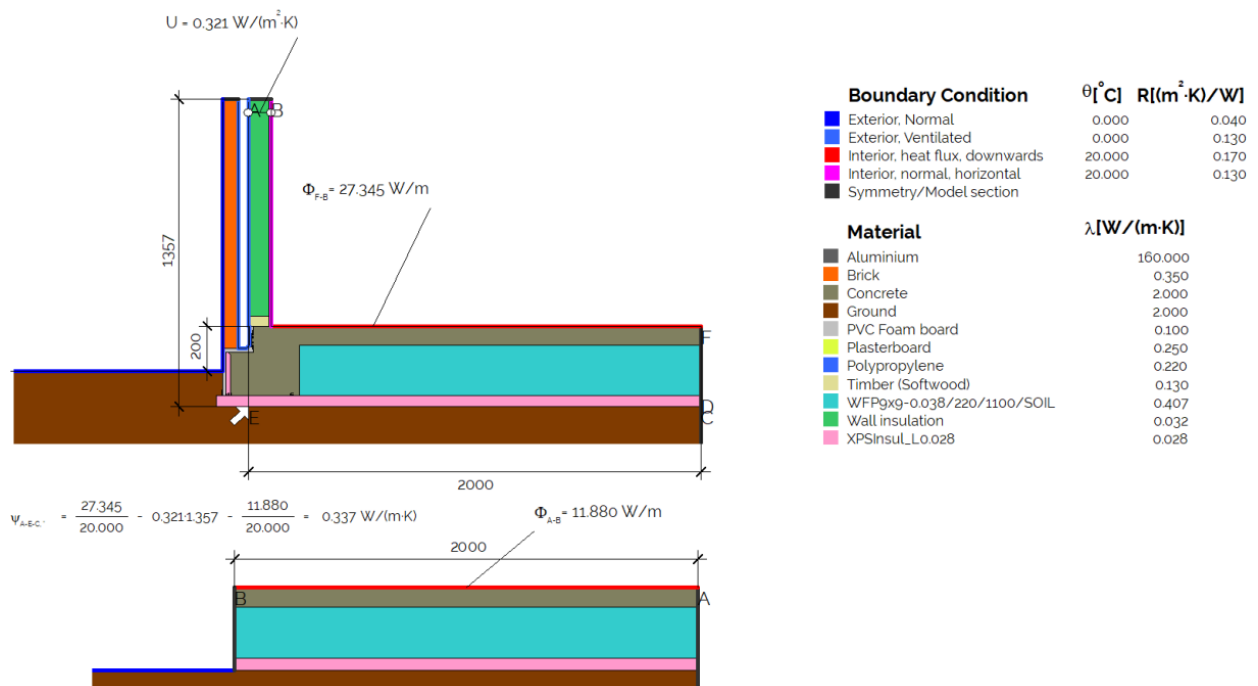

# QuickSet Rebate 120/305/75 with QPOD

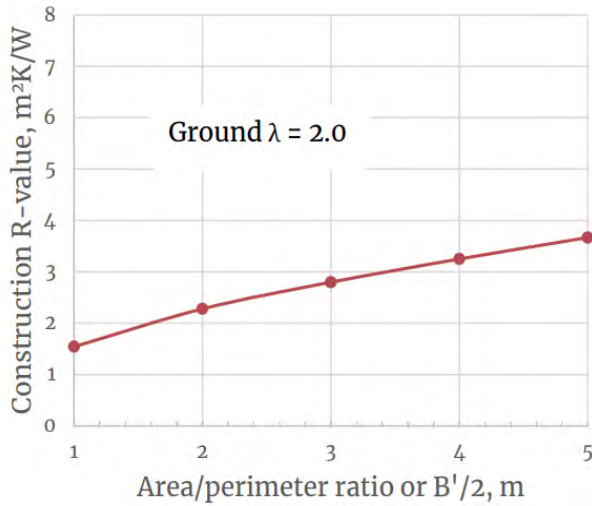
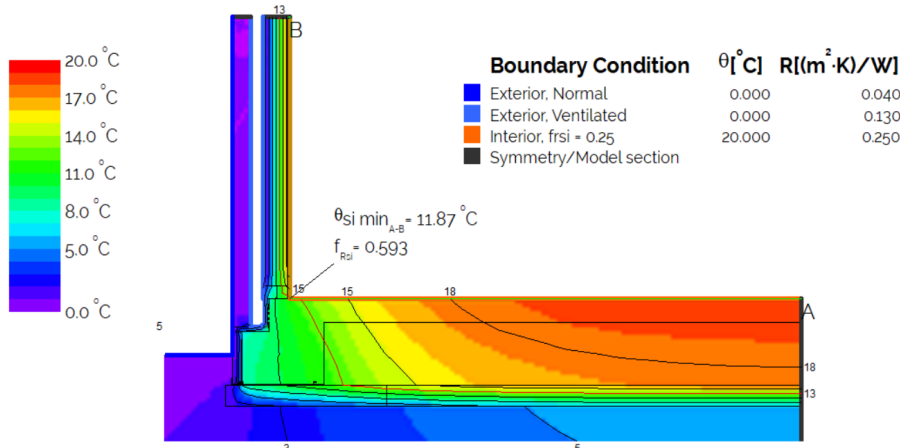

A/P, m	R-value, m²K/W
1	1.54
1.6	1.98
1.8	2.13
2	2.28
2.2	2.38
2.4	2.49
2.6	2.59
2.8	2.69
3	2.80
3.2	2.89
3.4	2.98
3.6	3.07
3.8	3.16
4	3.25
5	3.67

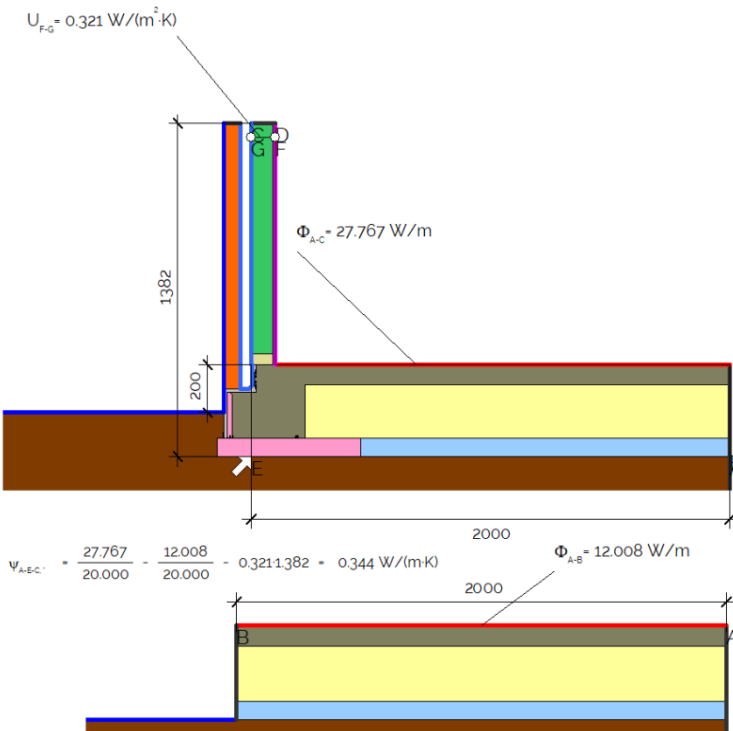

Boundary Condition	θ [°C]	R [(m²·K)/W]
Exterior, Normal	0.000	0.040
Exterior, Ventilated	0.000	0.130
Interior, heat flux, downwards	20.000	0.170
Interior, normal, horizontal	20.000	0.130
Symmetry/Model section		

  

Material	λ [W/(m·K)]
Aluminium	160.000
Brick	0.350
Concrete	2.000
EPS H	0.036
Ground	2.000
PVC Foam board	0.100
Plasterboard	0.250
Polypropylene	0.220
QPod_4open	1.050
Timber (Softwood)	0.130
Wall insulation	0.032
XPSInsul_L0.028	0.028

# QuickSet Rebate 120/305/75 with Polypod

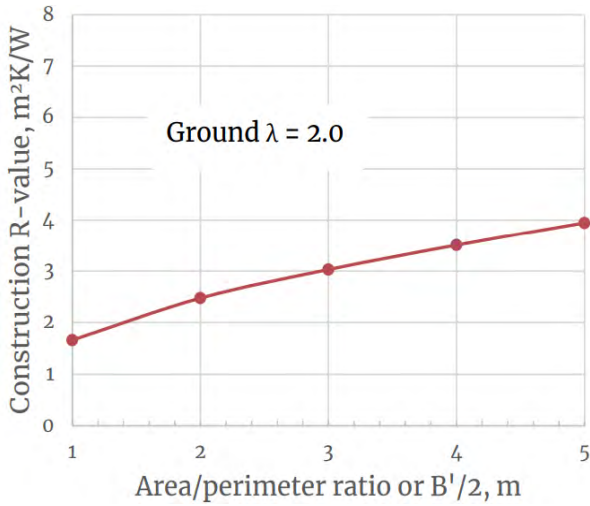
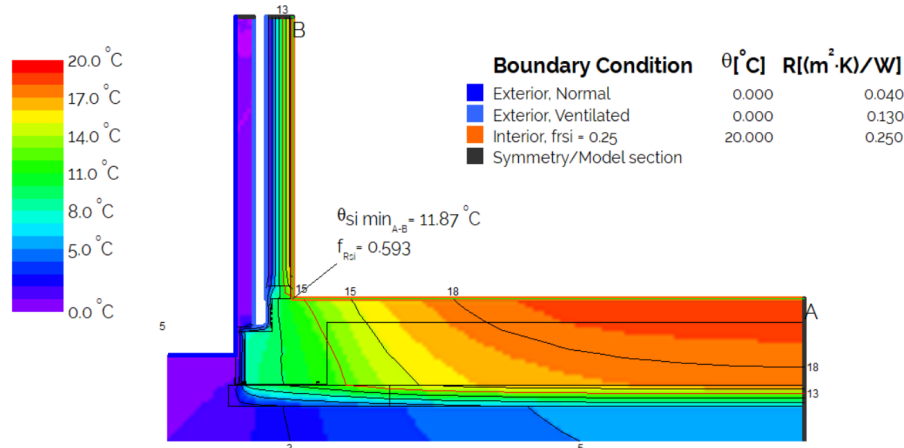

A/P, m	R-value, $\text{m}^2\text{K}/\text{W}$
1	1.66
1.6	2.15
1.8	2.31
2	2.47
2.2	2.59
2.4	2.70
2.6	2.81
2.8	2.92
3	3.03
3.2	3.13
3.4	3.22
3.6	3.32
3.8	3.41
4	3.51
5	3.95

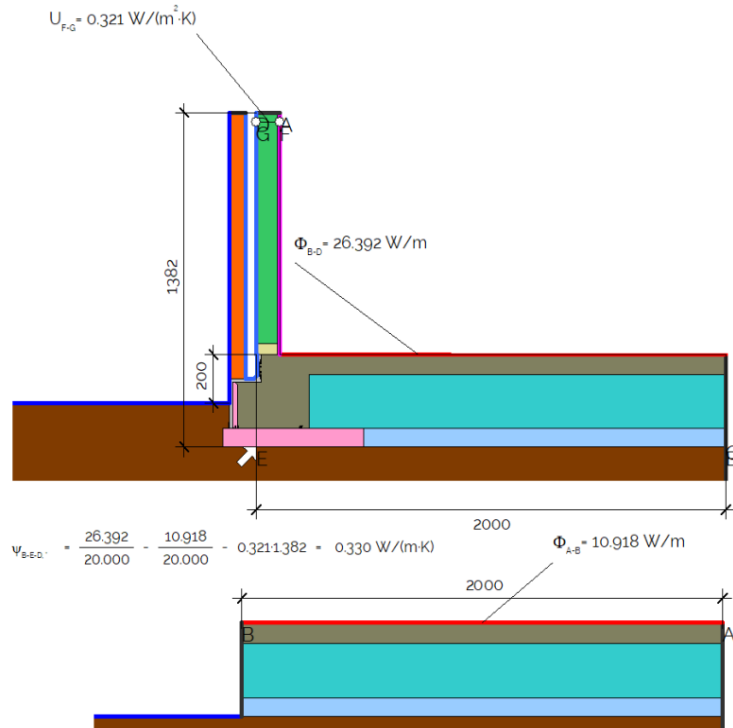

Boundary Condition	$\theta [^{\circ}\text{C}]$	$R [(\text{m}^2 \cdot \text{K})/\text{W}]$
Exterior, Normal	0.000	0.040
Exterior, Ventilated	0.000	0.130
Interior, heat flux, downwards	20.000	0.170
Interior, normal, horizontal	20.000	0.130
Symmetry/Model section		

Material	$\lambda [W]/(\text{m} \cdot \text{K})$
Aluminium	160.000
Brick	0.350
Concrete	2.000
EPS H	0.036
Ground	2.000
PVC Foam board	0.100
Plasterboard	0.250
Polypropylene	0.220
Timber (Softwood)	0.130
WFPg99-0.038/220/1100/SOIL	0.407
Wall insulation	0.032
XPSInsul_L0.028	0.028

# QuickSet Rebate 120/305/100 with Polypod

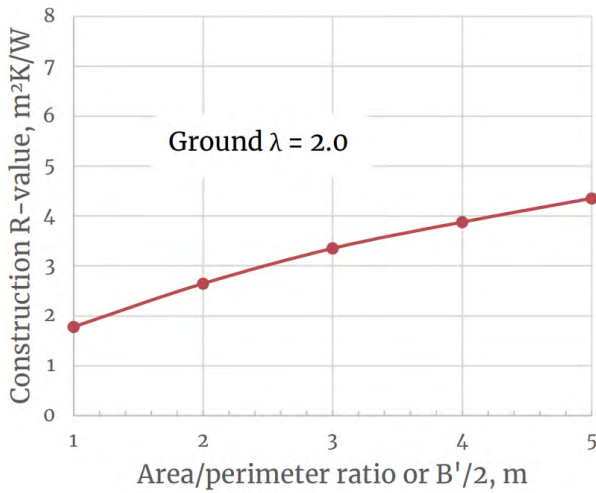
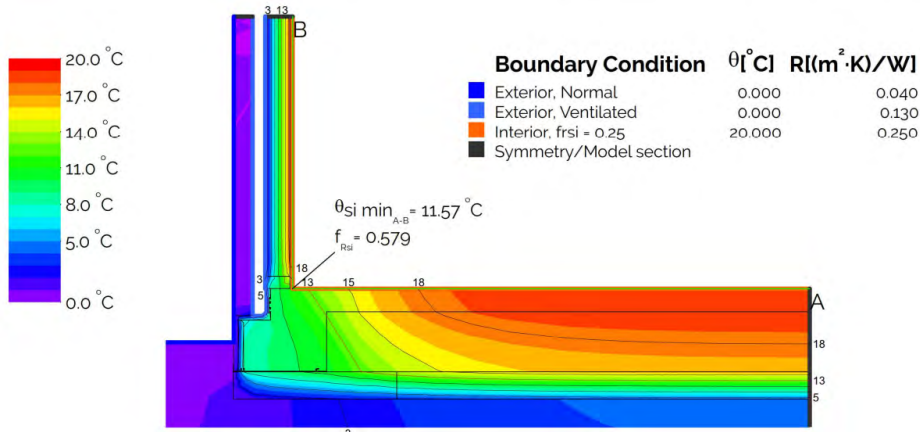

A/P, m	R-value, $\text{m}^2\text{K}/\text{W}$
1	1.78
1.6	2.30
1.8	2.47
2	2.65
2.2	2.79
2.4	2.93
2.6	3.07
2.8	3.21
3	3.35
3.2	3.46
3.4	3.56
3.6	3.67
3.8	3.77
4	3.88
5	4.35

$U = 0.321 \text{ W}/(\text{m}^2 \cdot \text{K})$

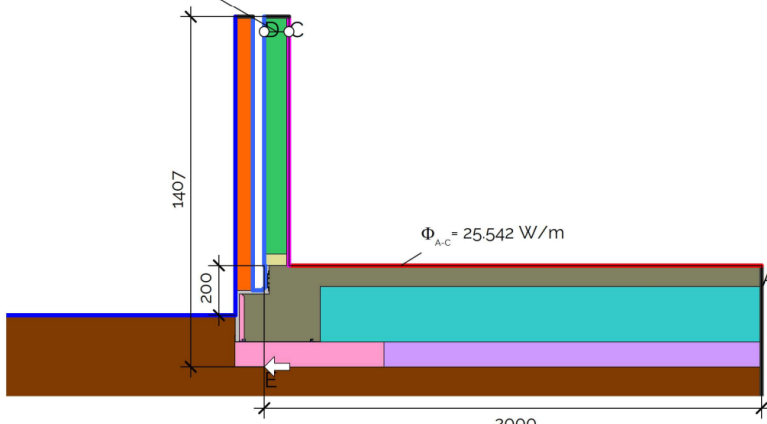

Boundary Condition	$\theta [^{\circ}\text{C}]$	$R[(\text{m}^2 \cdot \text{K})/\text{W}]$
Exterior, Normal	0.000	0.040
Exterior, Ventilated	0.000	0.130
Interior, heat flux, downwards	20.000	0.170
Interior, normal, horizontal	20.000	0.130
Symmetry/Model section		

Material	$\lambda [\text{W}/(\text{m} \cdot \text{K})]$
Aluminium	160.000
Brick	0.350
Concrete	2.000
EPS VH-grade	0.035
Ground	2.000
PVC Foam board	0.100
Plasterboard	0.250
Polypropylene	0.220
Timber (Softwood)	0.130
WFP9x9-0.038/220/1100/SOIL	0.407
Wall insulation	0.032
XPSInsuL_L0.028	0.028

$\psi_{A-E-C} = \frac{25542}{20.000} - \frac{9.005}{20.000} - 0.321 \cdot 1407 = 0.375 \text{ W}/(\text{m} \cdot \text{K})$

$\Phi = 9,005 \text{ W}/\text{m}$

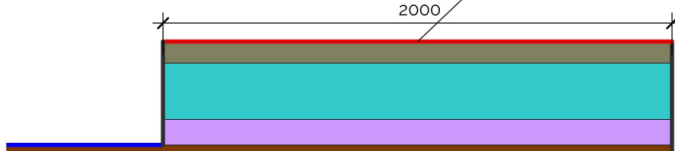

# QuickSet Rebate with Ultra 120/305/150 (Continuous SlabX200) with QPOD

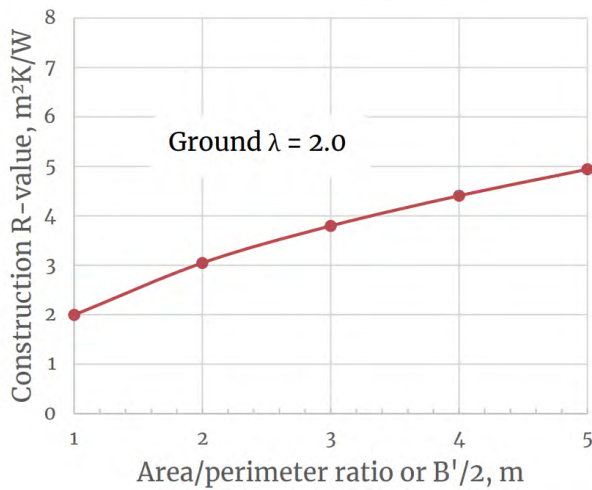
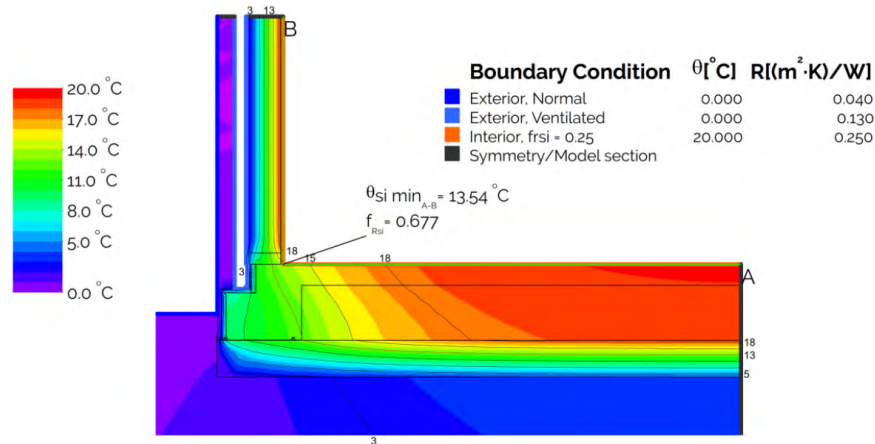

A/P, m	R-value, m²K/W
1	1.99
1.6	2.63
1.8	2.84
2	3.05
2.2	3.20
2.4	3.35
2.6	3.50
2.8	3.65
3	3.80
3.2	3.92
3.4	4.04
3.6	4.16
3.8	4.28
4	4.41
5	4.94

$U = 0.214 \text{ W}/(\text{m}^2 \cdot \text{K})$

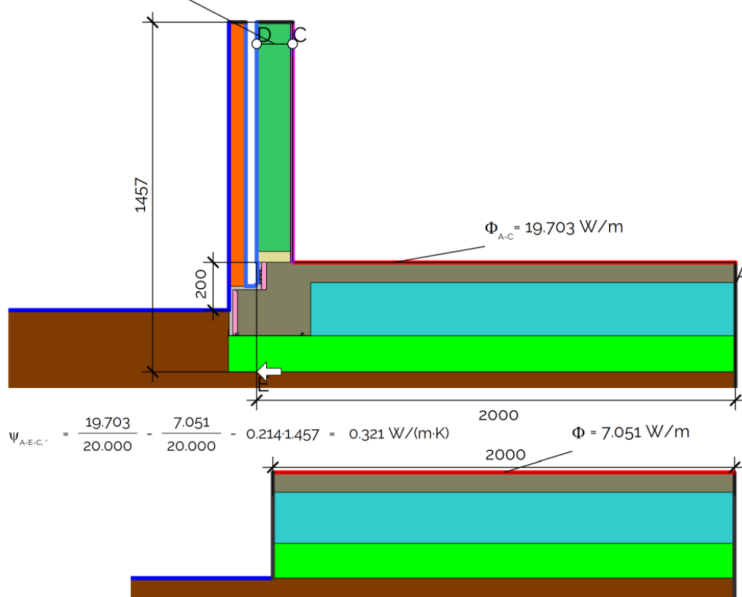

Boundary Condition	θ [°C]	R [(m²·K)/W]
Exterior, Normal	0.000	0.040
Exterior, Ventilated	0.000	0.130
Interior, heat flux, downwards	20.000	0.170
Interior, normal, horizontal	20.000	0.130
Symmetry/Model section		

  

Material	λ [W/(m·K)]
SlabX200	1.052
Aluminium	160.000
Brick	0.350
Concrete	2.000
Ground	2.000
PVC Foam board	0.100
Plasterboard	0.250
Polypropylene	0.220
SlabX200	0.034
Timber (Softwood)	0.130
Wall insulation	0.032
XPSInsuL_L0.028	0.028

# QuickSet Rebate with Ultra 120/305/150 (Continuous SlabX200) with Polypod

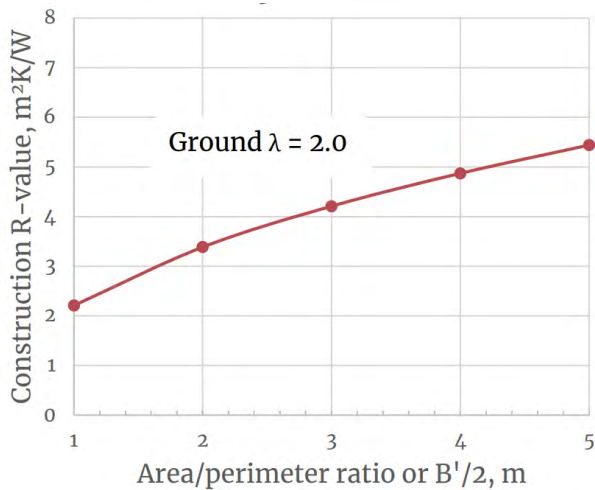
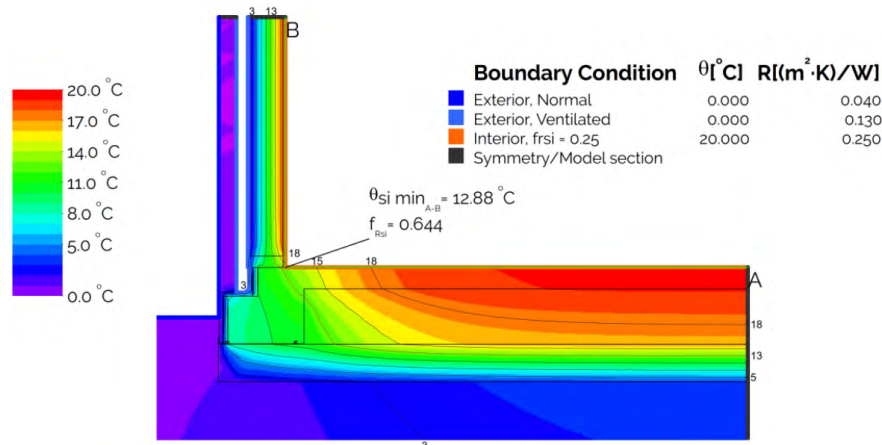

A/P, m	R-value, m²K/W
1	2.21
1.6	2.92
1.8	3.15
2	3.39
2.2	3.55
2.4	3.72
2.6	3.88
2.8	4.04
3	4.21
3.2	4.34
3.4	4.47
3.6	4.61
3.8	4.74
4	4.87
5	5.44

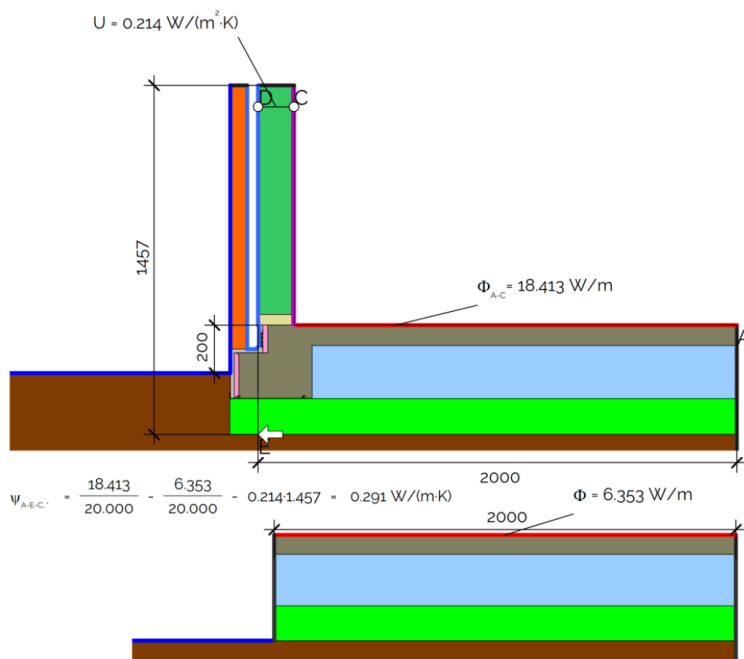

Boundary Condition	$\theta [^{\circ}\text{C}]$	$RI(\text{m}^2\cdot\text{K})/\text{W}$
Exterior, Normal	0.000	0.040
Exterior, Ventilated	0.000	0.130
Interior, heat flux, downwards	20.000	0.170
Interior, normal, horizontal	20.000	0.130
Symmetry/Model section		

Material	$\lambda [\text{W}/(\text{m}\cdot\text{K})]$
SlabX200	0.266
Aluminium	160.000
Brick	0.350
Concrete	2.000
Ground	2.000
PVC Foam board	0.100
Plasterboard	0.250
Polypropylene	0.220
SlabX200	0.034
Timber (Softwood)	0.130
Wall insulation	0.032
XPSinsul_L0.028	0.028

# Methodology

NZBC calculations are per the TBD NZBC H1 standard Verification Method H1/VM1 Appendix F summarized here:

Using internal slab dimensions in accordance with Equation 1 from this standard.

$$\text{Equation 1: } \text{slab area to perimeter ratio} = A_{\text{slab (internal)}} / P_{\text{slab (internal)}}$$

where  $A_{\text{slab (internal)}}$  is the area of the slab-on-ground floor that is part of the thermal envelope, measured between the interior surfaces of the walls that form the thermal envelope (m<sup>2</sup>) and  $P_{\text{slab (internal)}}$  is the perimeter of the slab-on-ground floor that is part of the thermal envelope, measured along the interior surfaces of the walls that form the thermal envelope, including the length of any wall(s) between conditioned and unconditioned spaces (m).

This is done using a two-dimensional numerical calculation in accordance with ISO 13370 Section 5.2b), a geometrical model in accordance with ISO 10211 Sections 7.3, 12.4.1 and 12.4.2 shall be used. The model shall have a floor width equal to half the characteristic dimension of the floor.

## COMMENTS:

1. The characteristic dimension of the floor (B, see ISO 13370) equals the area of the floor divided by half the perimeter of the floor and should be determined using internal dimensions.
2. A two-dimensional geometrical model with a floor width equal to half the characteristic dimension of the floor represents a floor that is infinitely long and has a width equal to the characteristic dimension of the floor, as required by ISO 13370 Section 5.2 b).

### F.1.2.5.

The calculation shall use the default values for the thermal properties of the ground from ISO 13370 Table 7, category 2. For other materials, thermal conductivity values from ISO 10456 shall be used and, for materials used below ground level, reflect the moisture and temperature conditions of the application. Values of surface resistance shall conform to ISO 13370 Section 6.4.3.

Note: Soil or Ground thermal conductivity = 2 W/(mK). The remaining thermal conductivities are shown in the results.

### F.1.2.6.

The construction R-value of the slab-on-ground floor shall be calculated according to Equation F.1.

$$\text{Equation F.1: } R_{\text{floor}} = 1 / U$$

where U is the temperature-specific heat flux through the internal floor surface of the two- or three-dimensional geometrical model, with the internal floor surface extending from the internal surface of the external wall to the cut-off plane of the floor (W/(m<sup>2</sup> · K)), determined by a numerical



calculation as per F.1.2.1 to F.1.2.5.

The below two graphs compare our implementation of the H1 methodology as compared to the BRANZ calculated table values in H1/AS1. They agree to within less than 2%. The small variation is from different finite element meshing routines. The results are given to two decimal places to help with interpolation but the accuracy only justifies a single decimal place and we'd recommend tables provided to designers show only a single decimal place (ie R1.33 show as R1.3).

### NZBC R-values for an Uninsulated Plain Concrete Slab

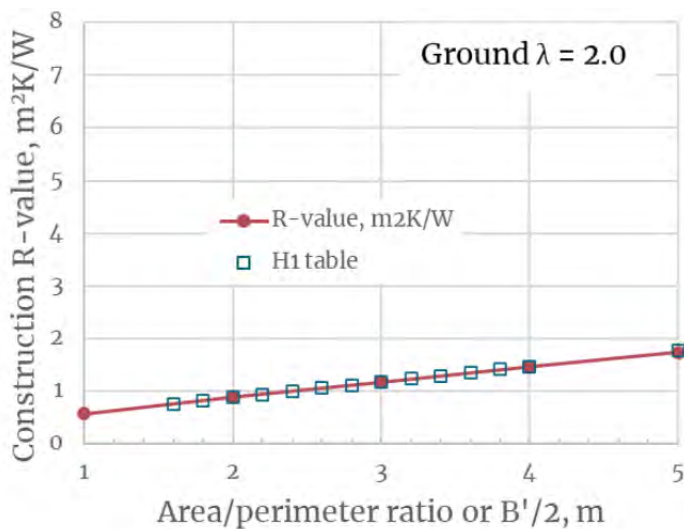

### NZBC R-values for an Uninsulated Raft (Waffle) Concrete Slab

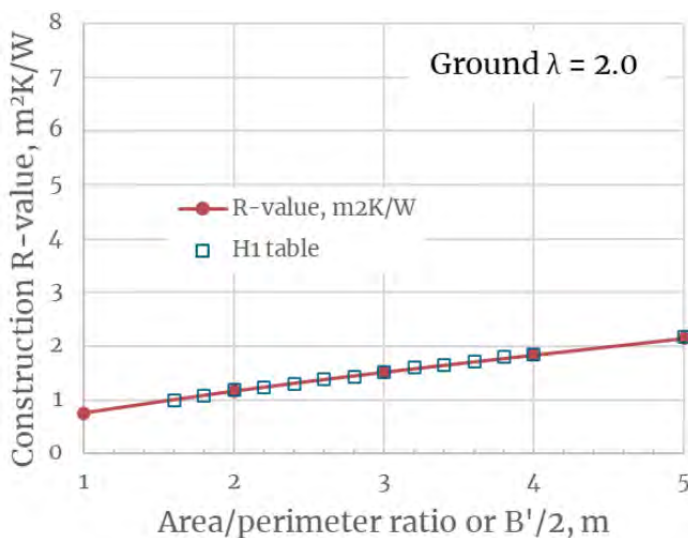

Both examples feature 90mm stud + 10mm gypsum wall board or 100mm wall.

Please note that the bottom waffle slab example has been created using a 300 mm pod system.

## Passive House $\Psi$ and fRSI

Slab Passive House calculations of  $\Psi$  are in accordance with ISO10211:2017 with Passive House Institute (PHI) modifications and the fRSI criteria. These use external dimensions and the heat loss at the sill plate (which should not be neglected) is included in this  $\Psi$  calculation. The NZBC has no official requirements for a particular fRSI value, but NZGBC Homestar V5 does have requirements intended to parallel the Passive House requirements. In PHPP10, these will be calculated via a moisture balance for each specific building to allow lower fRSI values to be used as less conservative criteria are appropriate with more detailed knowledge of the building ventilation rates, loads, and heating setpoints.

## fRSI Requirements for NZ Regions for Passive Homes

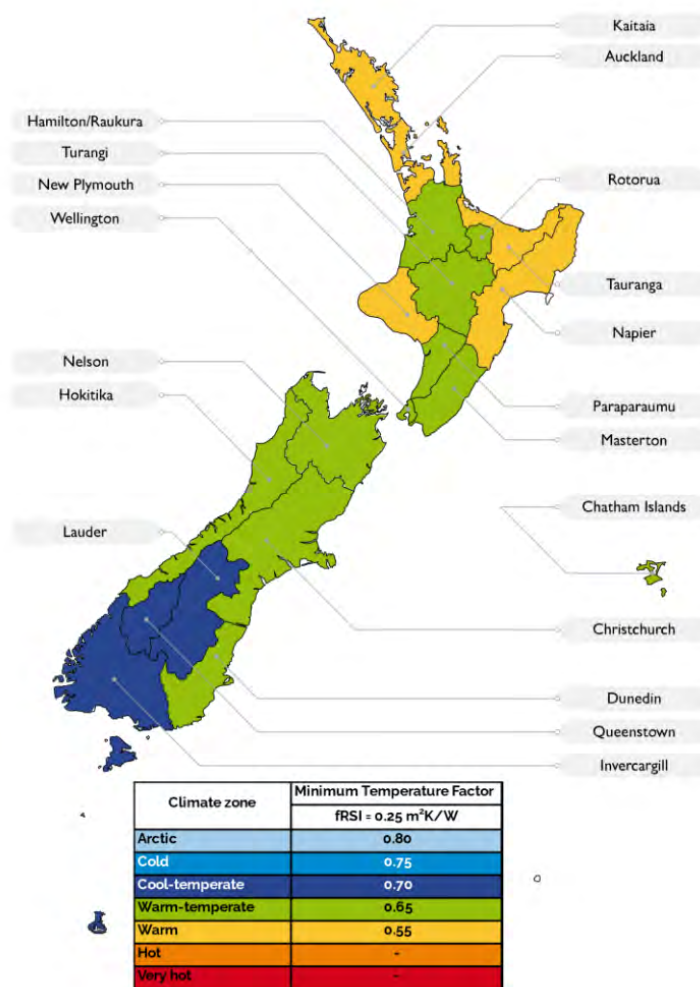

This map shows the three different fRSI zones at the weather station altitudes. The climate zone and thus the fRSI requirements also vary with altitude as the average temperatures typically drop by 0.6C per 100m of elevation gain. In general, these zones can be used without considering the elevation change.

Illustration from Sustainable Engineering Ltd.

fRSI requirements from the PHI Passive House Standard Building Criteria.